

# DLLI5I-DALI

Dry Contact Interface



## Specification Sheet

Gateways > Integration Devices



### Five-way DALI dry contact interface

The Dynalite DLLI5I-DALI enables mechanical and electronic switches to interface directly with a Dynalite DALI controller via the DALI bus.

## Key Features

---

- **DALI device** - Designed to operate seamlessly with the Dyalite DDBC120-DALI or DDBC320-DALI controller.
- **Powered directly by the DALI network** - Eliminates the need for additional network field wiring.
- **Five dry contact inputs** - Each dry contact trigger is individually programmable for a range of tasks.
- **Fully programmable** - Each individual input is fully software-programmable over the DALI network, supporting multiple functions such as lighting scene selection, room join, and toggling lighting on/off.
- **Compact size** - Inputs are presented on flyleads, making the device suitable for installation behind multi-gang switch grids.
- **Simple dry contact interface** - Can be used for low-level integration to third-party systems such as security and air conditioning, so that lighting can be coordinated with other services in the project.

## Dimensions

---

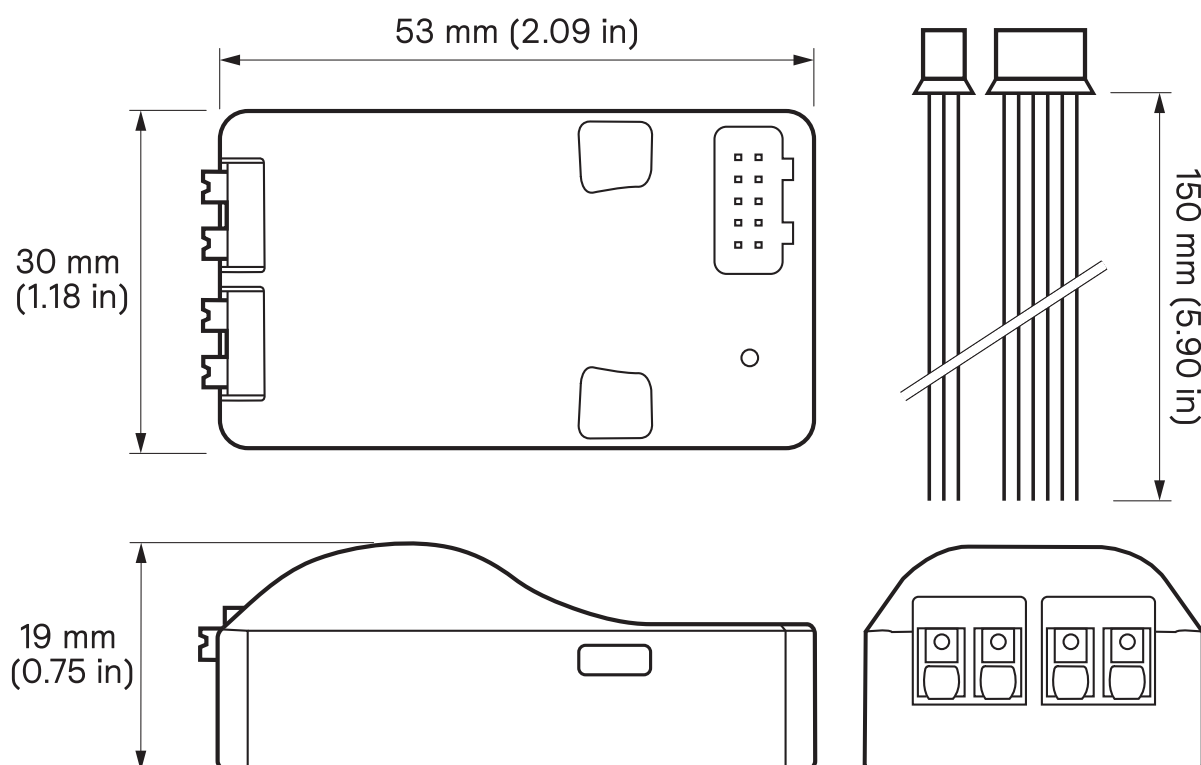

## Specifications

Electrical	
Supply Type	DALI
Supply Voltage	9.5-22.5 VDC
Supply Current	5.5 mA
IEC Overvoltage Category	III

Control	
Communication Ports	1 x DALI
Dry Contact Inputs	5

Physical	
Dimensions	19 x 53 x 30 mm (0.75 x 2.09 x 1.18 in)
Packed Weight	50 g (0.11 lb)
Construction	Plastic housing
Communication Ports	2 x two-way push-in terminal
Dry Contact Terminals	10 x flylead
Flylead Length	150 mm (5.9 in)

Environment	
Operating Temperature	0° to 50°C ambient (32° to 122°F)
Storage/Transport Temperature	-25° to 70°C ambient (-13° to 158°F)
Relative Humidity	≤90% non-condensing
IEC Pollution Degree	II
Installation Note	For indoor installation only

Compliance	
Certifications	CE, RCM, UL/cUL, FCC, ISED, UKCA, DALI-2
Sustainability	RoHS
IP Rating	IP20



Electrical Drawing

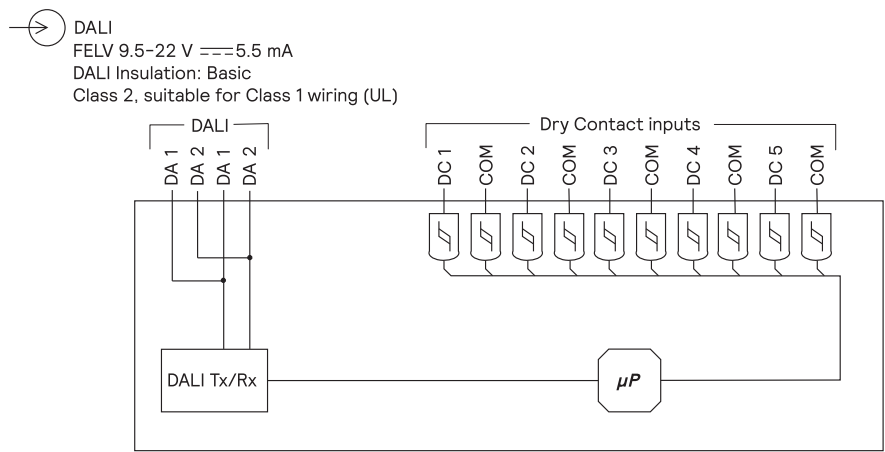

Ordering Codes

Product	12NC
DLLI5I-DALI	913703406209