

# Wired Systems

Preassembled DIN Rail Cabinets (UL)



## Installation Instructions

### Cabinet part codes:

DRC1220FR-GL-ENC	DBC516FR-ENC	DRPC1602-ENC	DMPC1602-ENC
DRC2420FR-GL-ENC	DBC120-DALI-ENC	DFPC802-ENC	DNG485-ENC
DBC1220-GL-ENC	DBC320-DALI-ENC	DFPC1602-ENC	PDEG-ENC
DBC2420-GL-ENC	DRPC802-ENC	DMPC802-ENC	PDEG-S-ENC



## IMPORTANT SAFEGUARDS

Failure to comply with these instructions may result in serious injury (including death) and property damage.



**Risk of Fire, Electrical Shock, Cuts, or other Casualty Hazards** - Installation and maintenance of this product must be performed by a qualified electrician. This product must be installed in accordance with the applicable installation code by a person familiar with the construction and operation of the product and hazards involved. For continued protection against shock hazard replace all covers and guards after field wiring is completed.



**Safe work practices** - Before installing or performing any service, the power MUST be turned OFF at the branch circuit breaker. According to NEC 240.83(D), if the branch is used as the main switch for a lighting circuit, the circuit breaker should be marked with "SWD". All installations should be in compliance with the National Electrical Code and all state and local codes.



**Risk of Fire and Electric Shock** - Make certain power is OFF before starting installation or attempting any maintenance. Disconnect power at fuse or circuit breaker. Dynalite load controllers may contain circuits from more than one power source.



**Risk of Burn** - Disconnect power and allow fixture to cool before handling or servicing.



**Risk of Personal Injury** - Due to sharp edges, handle with care. Always use at least two people when lifting and mounting heavy or large units.

**DISCLAIMER OF LIABILITY:** Signify and its subsidiaries assumes no liability for damages or losses of any kind that may arise from the improper, careless, or negligent installation, handling or use of this product.

**IMPORTANT:** Read carefully before installing devices and fixtures. Retain for future reference.

**NOTICE:** Do not use this equipment for other than the intended use.

**NOTICE:** Specifications and dimensions subject to change without notice.

**ATTENTION Receiving Department:** Note actual device descriptions and any shortage or noticeable damage on delivery receipt. File claim for common carrier (LTL) directly with carrier. Claims for concealed damage must be filed within 15 days of delivery. All damaged material, complete with original packing must be retained.

**NOTICE:** If a room is wired for two circuits using two separate hot leads, it is very important to connect only one circuit per relay. Both circuits must be fed from the same phase.

**NOTICE:** Ensure that all devices are firmly seated on the DIN rails before beginning field wiring. To remount a device simply pull the black tab(s) away from the DIN rail, push down on the side of the device with the tab and allow the tabs to snap back into place.

**NOTICE:** Caution, 0-10 V and DALI wires may not be SELV/Class 2 (UL) and should never be considered touch safe. Basic insulation or higher is required between 0-10 V/DALI wires and mains cabling.

**NOTICE:** Ensure that the supply is fully isolated at an external breaker before opening doors. Test that power has been removed before starting to handle conductors.

**NOTICE:** Ensure that high voltage and low voltage wiring remains separate.

**NOTICE:** All new wiring must be fully verified before applying power.

**NOTICE:** Output ratings vary for different load types. Check individual device compliance and ratings before installation.



## Overview – please read

The Dynalite DIN Rail Cabinets (panels) consist of an enclosure with premounted interior DIN rail devices. The panels are designed, built, and tested to strict safety regulations. By following the installation steps within this guide, you can ensure safe installation and operation of these lighting control devices.

- The installation must comply with the appropriate electrical codes and regulations in force in your area.
- Dry location rated. Designed for indoor installation and use only. The units can, however, be used to control appropriately certified exterior lighting fixtures.
- Ensure that all wiring conforms to local specifications and is sufficiently rated for the installation.
- All new wiring must be fully verified before applying power.
- The high voltage supply should be fed to the cabinet via an external isolation breaker with sufficient capacity for the planned installation.
- Due to vertical mounting, all devices have been derated by 30% (40% for DDMC802) to meet the total box load.

### Installation steps:

1. Mount enclosure
2. Connect power wiring
3. Connect relay wiring
4. Connect 0-10 V and/or DALI control wiring
5. Connect RS-485 DyNet network wiring

- Remove packaging material and discard before beginning field wiring.
- Devices do not include branch circuit overcurrent protection. Each relay has a default 4kA SCCR rating. Bussman KTK-R class CC fuse protection can increase SCCR rating. Suitable overcurrent protection must be provided by the installer.
- Always use at least two people when lifting and mounting heavy or bulky units.
- Ensure that the supply is fully isolated at an external breaker before opening doors. Test that power has been removed before starting to handle conductors.
- Ensure that high voltage and low voltage wiring remains separate. The design of the cabinets allows line voltage field wiring to enter and exit through the knockouts provided at the left and right sides of the cabinet, while low voltage wiring can enter and exit the cabinet through knockouts at the top and bottom of the cabinets.

6. Connect Ethernet cable to gateway.
7. Clear all power circuit wiring for errors
8. Energize device power circuit
9. Energize relay and lighting power circuits
10. Check correct system operation

## Dimensions

### Cabinet type: ULC 1

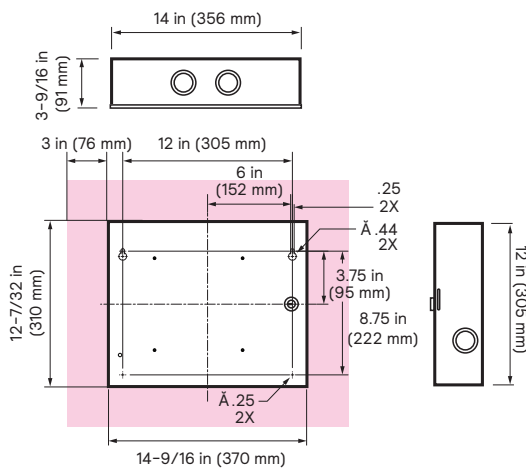

Indicates minimum clear space required.

### Cabinet type: ULC 2

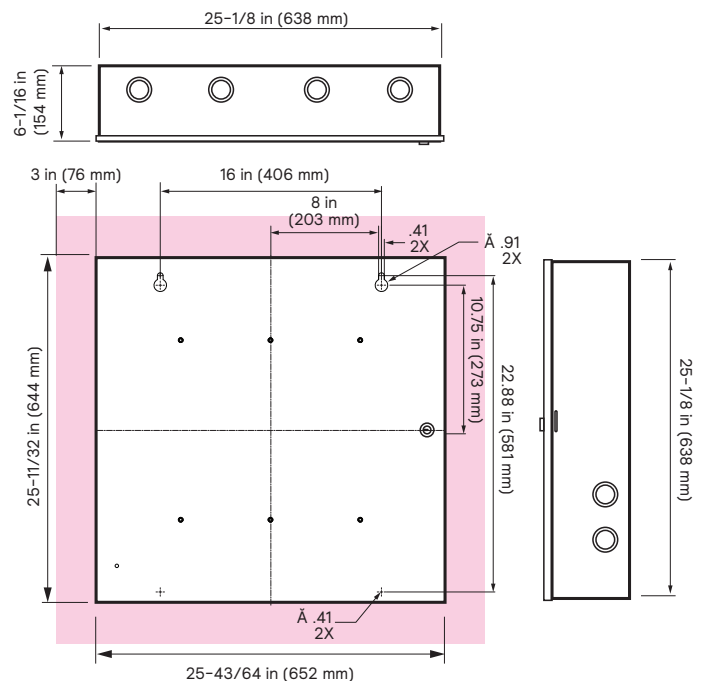

## DIN rail cabinets (UL)

Cabinet part code	Cabinet type	Included Devices	Output Description	Derated Total Box Load
DRC1220FR-GL-ENC	ULC 1	DDRC1220FR-GL	12 x 20 Amp Relay Outputs	130 Amps
DRC2420FR-GL-ENC	ULC 1	2 x DDRC1220FR-GL	24 x 20 Amp Relay Outputs	130 Amps per DDRC1220FR-GL
DBC1220-GL-ENC	ULC 1	DDBC1200	12 x 1-10 V/DALI Broadcast Outputs (12 x DALI Lines)	420 mA
		DDRC1220FR-GL	12 x 20 Amp Relay Outputs	130 Amps
DBC2420-GL-ENC	ULC 2	2 x DDBC1200	12 x 1-10 V/DALI Broadcast Outputs (12 x DALI Lines)	420 mA per DDBC1200
		2 x DDRC1220FR-GL	24 x 20 Amp Relay Outputs	130 Amps per DDRC1220FR-GL
DBC516FR-ENC	ULC 1	DDBC516FR	5 x 16 Amp Relay Outputs 5 x 1-10 V/DALI Outputs (1 x DALI Line)	11 Amps per relay output, 20 mA per DALI output 10 mA (sink/source) per 1-10 V output per driver output
DBC120-DALI-ENC	ULC 1	DDBC120-DALI	1 x 16 Amp Relay Output 1 x DALI Addressable Output	11 Amps per relay output, 160 mA per driver output
DBC320-DALI-ENC	ULC 1	DDBC320-DALI	3 x 16 Amp Relay Outputs 3 x DALI Addressable Outputs	11 Amps per relay output, 160 mA per driver output
DRPC802-ENC	ULC 1	DDMC802	Modular Controller with selectable modules	10 Amps
		2 x DGTM402 modules	8 x 2 Amp Reverse-Phase Outputs	Not compatible with magnetic transformers. Apply de-rating for electronic and LED loads.
DRPC1602-ENC	ULC 1	2 x DDMC802	Modular Controllers with selectable modules	10 Amps per DDMC802
		4 x DGTM402 modules	16 x 2 Amp Reverse-Phase Outputs	Not compatible with magnetic transformers. Apply de-rating for electronic and LED loads.
DFPC802-ENC	ULC 1	DDMC802	Modular Controller with selectable modules	10 Amps
		2 x DGLM402 modules	8 x 2 Amp Forward-Phase Outputs	Can be limited by load capacitance. Apply de-rating for electronic and LED loads.
DFPC1602-ENC	ULC 1	2 x DDMC802	Modular Controllers with selectable modules	10 Amps per DDMC802
		4 x DGLM402 modules	16 x 2 Amp Forward-Phase Outputs	Can be limited by load capacitance. Apply de-rating for electronic and LED loads.
DMPC802-ENC	ULC 1	DDMC802 (No modules fitted)	Modular Controller with selectable modules	Module dependent, up to 10 Amps
DMPC1602-ENC	ULC 1	2 x DDMC802 (No modules fitted)	Modular Controllers with selectable modules	Module dependent, up to 10 Amps per DDMC802
DNG485-ENC	ULC 1	DDNG485	1 x RS-485 DyNet (12 V <sub>DC</sub> ) 1 x RS-485 DyNet/DMX512 (12 V <sub>DC</sub> )	200 mA (Port 2 output)
		DSP10-15	15 V <sub>DC</sub>	670 mA (90-264 V <sub>AC</sub> supply)
PDEG-ENC	ULC 1	PDEG	1 x Ethernet (10/100 BaseT) 1 x RS-485 DyNet (12 V <sub>DC</sub> )	200 mA (RS-485 output) when powered from DC power supply
		DSP10-15	15 V <sub>DC</sub>	670 mA (90-264 V <sub>AC</sub> supply)
PDEG-S-ENC	ULC 1	PDDEG-S (BACnet Gateway)	1 x Ethernet (10/100 BaseT), BACnet 1 x RS-485 DyNet (12 V <sub>DC</sub> )	300 mA (RS-485 output)

## Mounting the enclosure

1. Choose a dry location convenient to the circuit breaker panel that meets the operating temperature requirements.
2. Mount the enclosure on a firm surface using the pre-drilled holes.
3. Connect the enclosure to the circuit breaker panel using conduit.
4. Ensure that there is at least 3 inches (76 mm) of air space around the wired enclosure.
5. Remove all cuttings and dirt.

### Mounting Considerations

- The cabinets are designed for surface mounting. Consult Dynalite support for flush mounting options.
- Use suitable conduits and couplers to link the raceways to the controller chassis.
- Allow adequate space for future maintenance of the unit. Do not install in a location that will later be difficult to access.
- During operation, the cabinets will produce clicks during relay switching. Take this into consideration when deciding on a suitable mounting position.

- Cabinets are designed to be mounted vertically.
- A minimum of 14 inches (360 mm) must be maintained from the front of the chassis to any other components or walls. Please make sure to check and follow local code requirements if additional clearance is needed per code in your area.
- The cabinets are all fully convection cooled; they do not contain fans. Therefore, it is vitally important to ensure that each cabinet is installed in a ventilated location that permits sufficient airflow and provides the correct operating conditions.
- Locating cabinets away from heat generating equipment will benefit long term reliability of all devices.

## Connecting the supply

The main supply conductors enter at the top panel. Input power is then fed to the devices inside the cabinet.

The suggested entry point for the supply wiring is via the rightmost knockout on the top of the chassis. This provides immediate access to the circuit breaker that supplies the devices with power. Use a suitable conduit and coupler to feed the source wiring safely into the chassis.

See the diagram on the right for connection details. The main earth terminal is located near to the neutral lug. The earth connection is bonded to the main backplane of the chassis and the outer panels.

Please consult the power terminal block drawing for details about the maximum permissible supply wire gauges.

**Note:** Check the stated voltage rating of the controller before connecting to the supply and check that it matches the supply voltage.

### Power Terminal Block

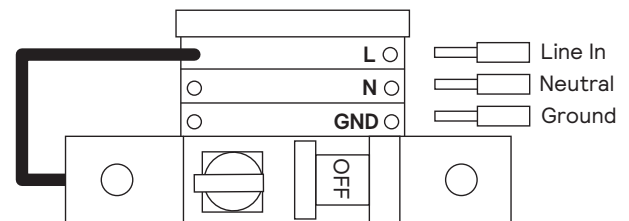

### Wiring Information:

Strip wire: 1/2" to 5/8"

Wire size: 12-10 AWG (3-5 mm<sup>2</sup>)

Solid/stranded copper only

### Supply voltage

Panels with DDBC320-DALI or PDDEG-S:

100-277 V $\sim$  0.5 A

All other panels:

100-240 V $\sim$  0.5 A

## Run the wiring

All cabinets have been designed to provide a clear layout and logical progression for all power circuits. Field wiring for branch circuits that are connected to the dimmers and relay controllers, enter from the sides of the cabinet. Ground connections are provided at the top of the cabinet for landing grounding conductors.

### Connecting Relay loads

The relay controllers will be pre-mounted on the interior DIN rail per the order specifications. Unless otherwise specified, latching relays (single pole) are provided for connection to lighting loads.

Prior to relay connection, test the load directly connected to the branch circuit breaker to verify that there are no shorts. Remove all wire cuttings from the enclosure.

Relays are numbered 1-12 on the controller. System Builder commissioning software is used to program each relay to meet control requirements. The table below indicates the minimum wires size to be used with various load currents.

Minimum AWG	Cabinet type
10	ULC 2
12	ULC 1
Use 75°C wire insulation minimum. Use copper conductors only.	
20 A max load per channel	
130 A max load per DDRC1220FR-GL	

### Connecting 0/1-10V Dimmer loads

10 V dimmer outputs are connected to drivers in a circuit. Ensure that wire polarity is consistent on each driver. Each 10 V output requires a corresponding relay on the dimmer to turn the lighting load ON/OFF. This mapping is performed during programming.

### Connecting DALI loads

On controllers named with the -DALI suffix, the two wire DALI addressable bus may be connected to (Sensor and Dry Contact) input devices that have a DALI interface and to individually addressable DALI drivers. Each two wire DALI addressable bus supports up to 64 DALI drivers and up to 16 DALI devices (refer to Input Devices/Drivers table on page 9). DDBC516FR outputs are selectable between DALI addressable or DALI Broadcast. DDBC1200 outputs are DALI Broadcast only.

Use 16 AWG (1.5 mm<sup>2</sup>) cable for the two-wire addressable bus and do not exceed 984ft (300 meters). The two wire DALI bus is polarity and topology free and provides 250mA per bus to power addressable devices.

### Connecting RS-485 control wiring

The lighting control network wiring is connected to the fly lead between the devices and then is daisy-chained outside of the cabinet to other devices in the network.

For the DDNG516FR, the RS-485 wiring is connected from the DINGUS-PDRAS-RJ45-TRIPLE via RJ45 connectors to other devices.

For other devices, connect a DINGUS-DUS-RJ45-DUAL to the fly lead to use cables with RJ45 connectors. The maximum recommended length for RS-485 DyNet cables between two network bridges is 2620 ft (800 m).

For cable runs over 1000 ft (300 m), (or baud rates over 9600 bps), install 120 Ohm, 2 W end-of-line resistors across the D+ and D- terminals of the DyNet connector strip on the first and last devices. Belden 1502R or 1502P cable is recommended.

For DMX512 networks, add a 120 Ohm, 0.5 W termination resistor across D+ and D- on the last DMX512 device.

## Wiring flow

Cabinet type: ULC 1

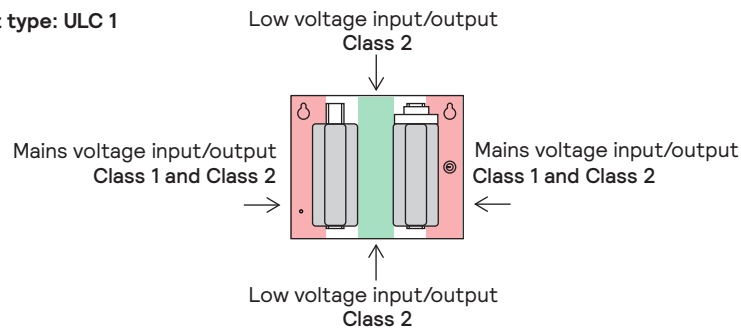

Cabinet type: ULC 2

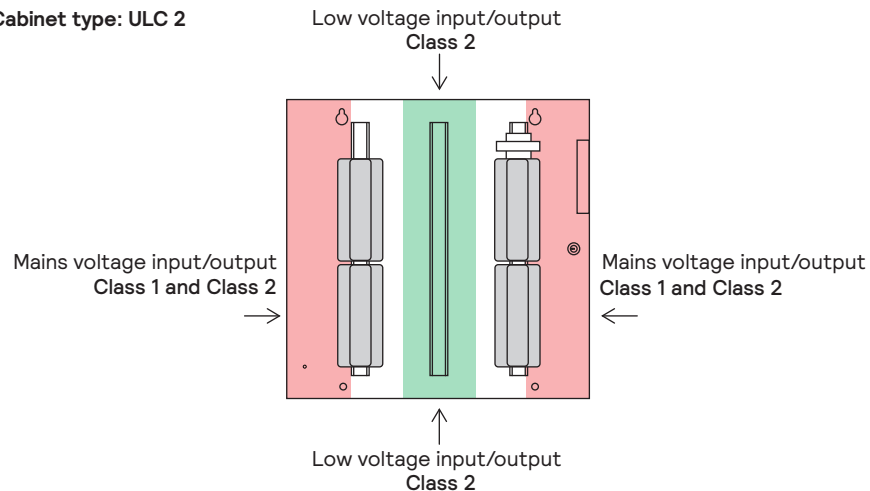

## Wiring flow

### Internal wiring example – AC powered devices

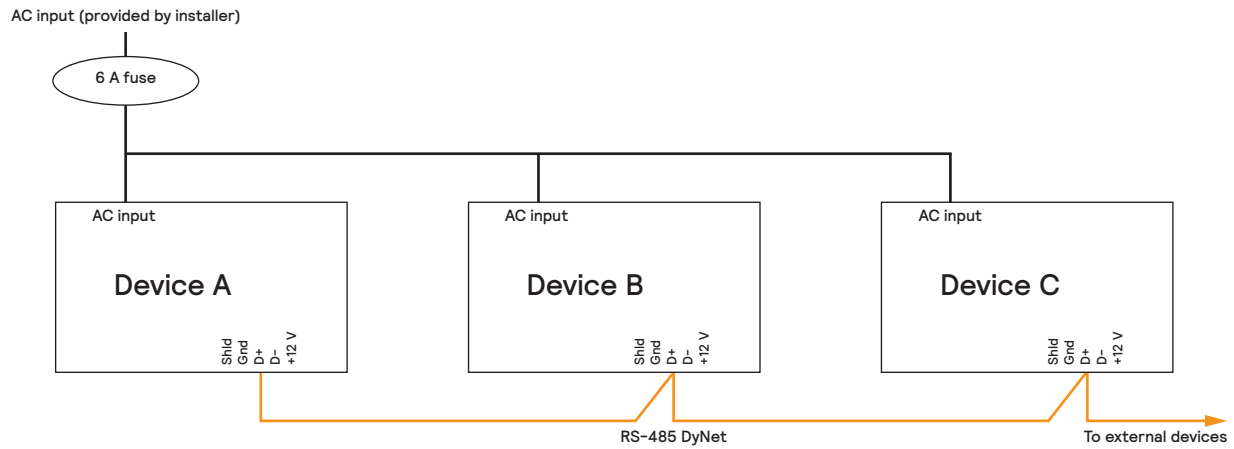

### Internal wiring example – DC powered devices

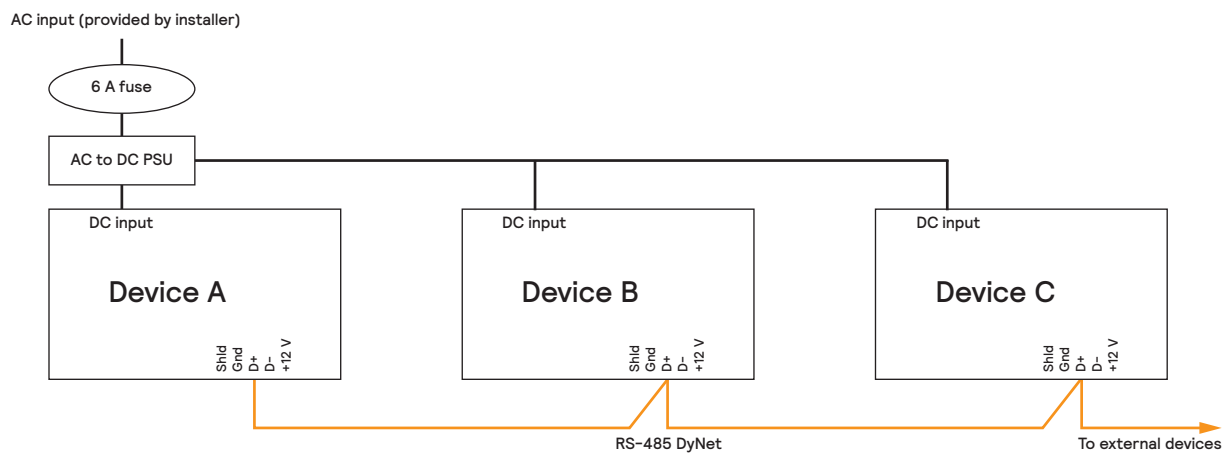

### Internal wiring example – DDMC802 devices

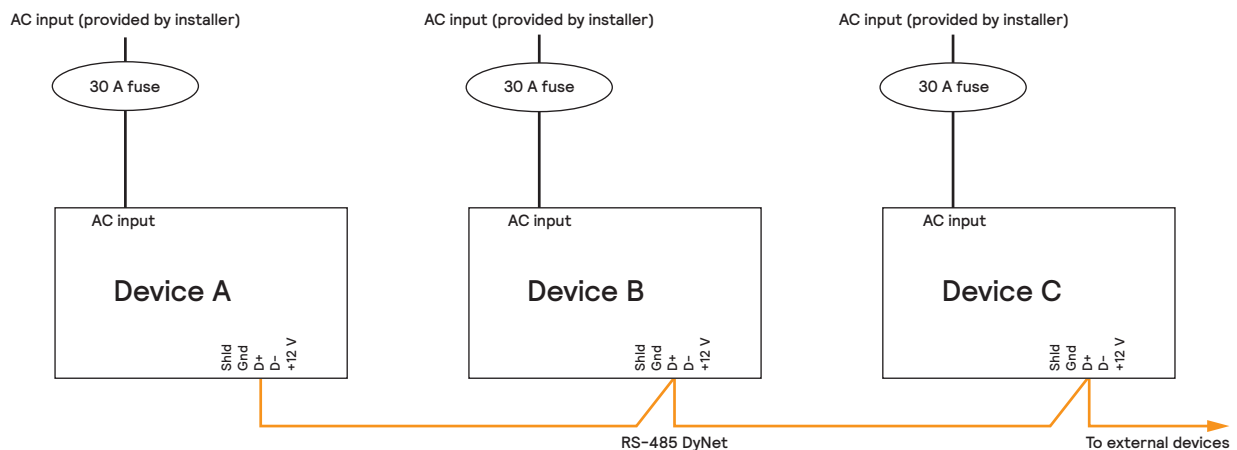





# Device wiring

## 0/1-10 V / DALI Controllers

### DDBC1200

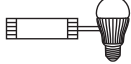



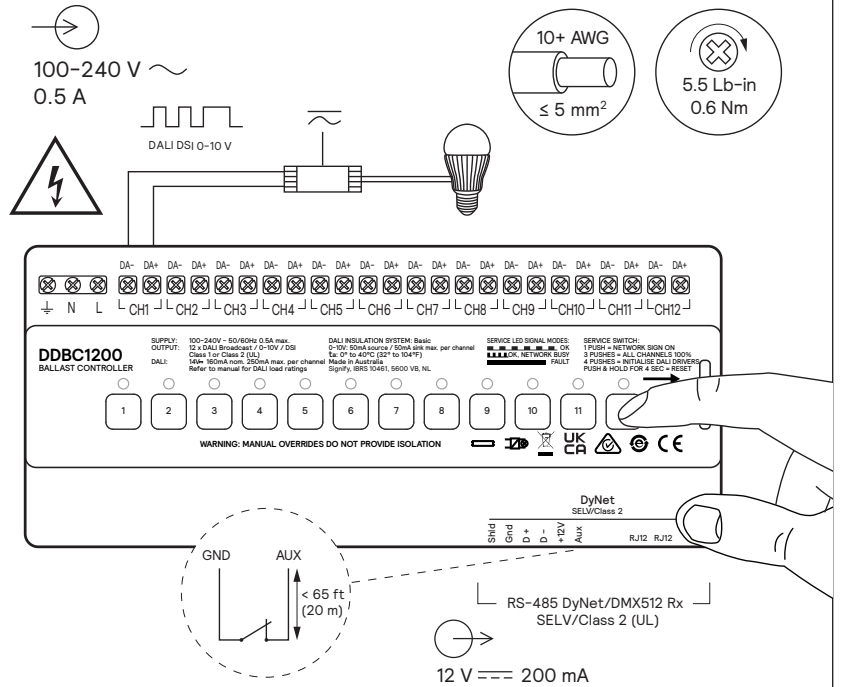

#### Control Channel Ratings

		
<b>DALI Broadcast</b>	≤ 80/CH Guaranteed 160 mA Maximum 250 mA Insulation: basic	≤ 300
<b>DSI</b>	≤ 80/CH	≤ 300
<b>0-10 V</b>	Sink 50 mA Source 50 mA	Driver dependent



### DDBC516FR

#### Output Ratings/Channel (CH)



Load Type	CH1-CH5
 General Use	16 A, 277 V ~
 Incandescent	
 Standard Driver	
 Electronic Driver	
 Motor	16 FLA (1 HP), 120 V ~ 14.5 FLA (2 1/2 HP), 240 V ~ 14.1 FLA (3 HP), 277 V ~
 Pilot Duty	6 A, 120 V ~ 3 A, 240 V ~ 2.6 A, 277 V ~

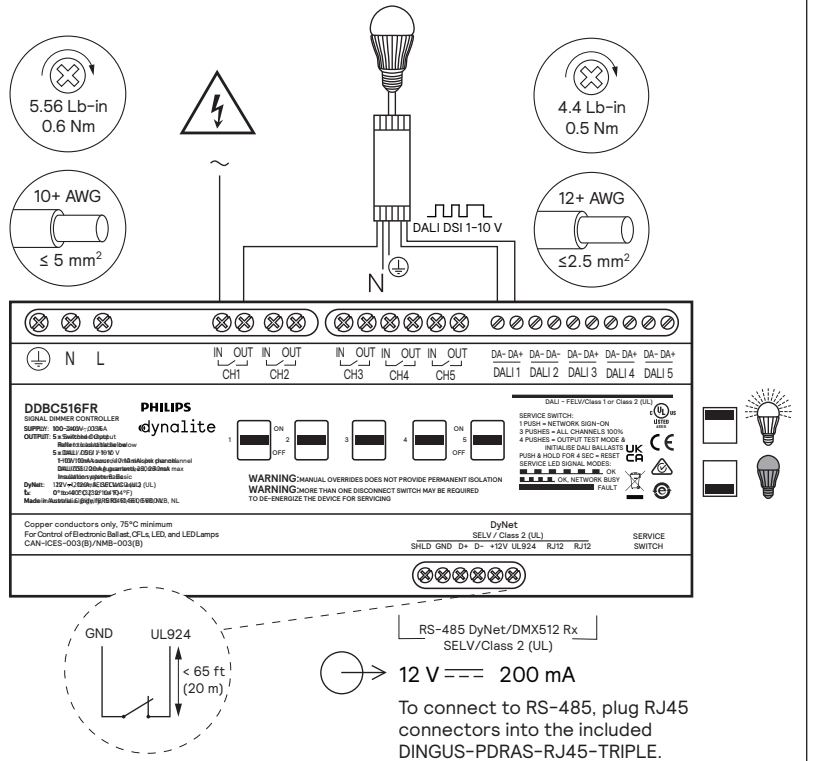

CH-CH ≤ 300 V ~ (UL) / 400 V ~ (CE)

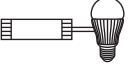

#### Control Channel Ratings

		
<b>DALI Addressable and Broadcast</b>	≤ 10/CH Guaranteed 20 mA Maximum 250 mA Insulation: basic	≤ 50
<b>DSI</b>	≤ 10/CH	≤ 50
<b>1-10 V</b>	Sink 10 mA Source 10 mA	Driver dependent

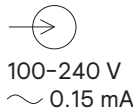

! For relay loads supplied from 3 x 277 V/480 V mains, you must leave a one channel gap between channels when they are on different phases.

# Device wiring

## DALI-2 Controllers

### DDBC120-DALI Output Ratings/Channel (CH)

Load Type	
Electronic Driver	16 A, 277 V ~ (UL) 20 A, 240 V ~ (CE)
Inrush Current	500 A

1 ~ 3 ~  
100-240 V ~  
0.25 A

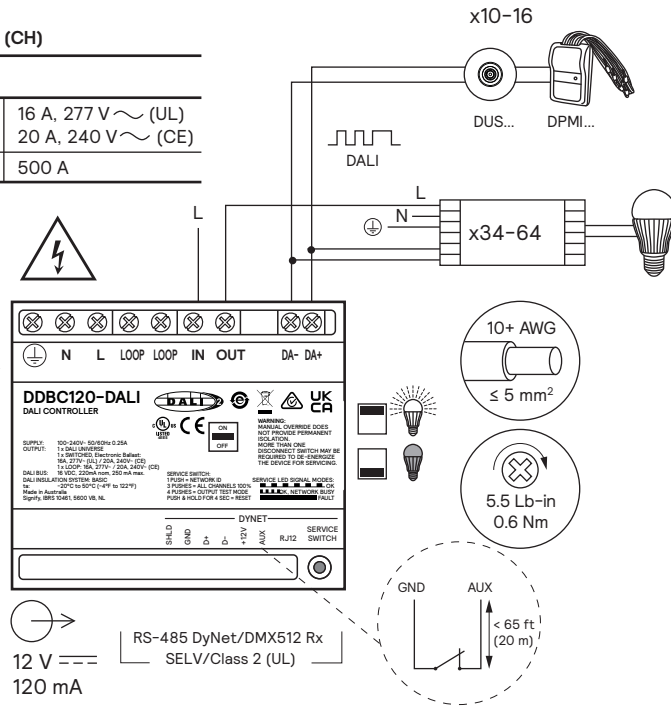

### Control Channel Ratings

DALI Addressable	
	$\le 64/\text{CH}$
	Guaranteed 220 mA Maximum 250 mA
	Insulation: basic
	Auto restart on DALI output overload or short circuit

### Input Devices/Drivers

10	64	
11	59	
12	54	
13	49	
14	44	
15	39	
16	34	

### DDBC320-DALI

1 ~ 3 ~  
CH-CH < 500 V ~

100-277 V ~  
0.5 A

### Output Ratings/Channel (CH)

Load Type	CH1-CH3
Electronic Driver	16 A, 277 V ~ (UL) 20 A, 240 V ~ (CE)
Pilot Duty	6 A, 120 V ~ 3 A, 240 V ~ 2.6 A, 277 V ~
Inrush Current	500 A

### Control Channel Ratings

DALI Addressable		
	$\le 64/\text{Universe}$	$\le 192$
	Guaranteed 220 mA Maximum 250 mA	
	Insulation: basic	

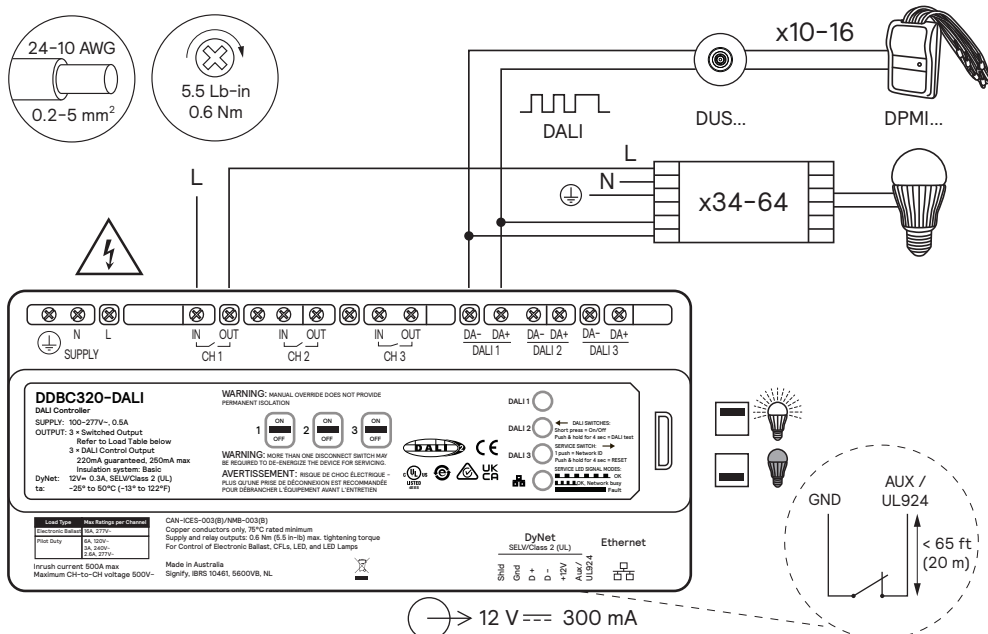

### Input Devices/Drivers

10	64	
11	59	
12	54	
13	49	
14	44	
15	39	
16	34	

Modular Controllers

DDMC802

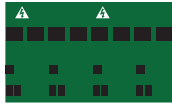

DGTM402  
4 x 2 A  
Reverse-phase  
dimmer module

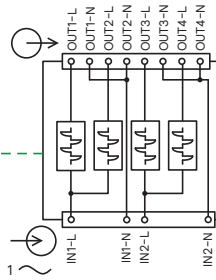

100-240 V ~  
16 A

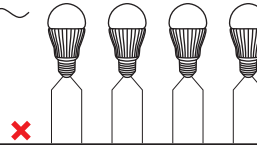

10+ AWG  
≤ 5 mm<sup>2</sup>

5.5 Lb-in  
0.6 Nm

Load Type	Output Ratings Per Channel
Incandescent	2 A, 120 (UL) / 230 V ~
Electronic Driver	2 A, 120 (UL) / 230 V ~

Not compatible with magnetic transformers.  
Apply de-rating for electronic and LED loads.

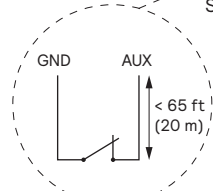
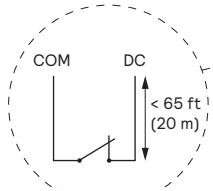
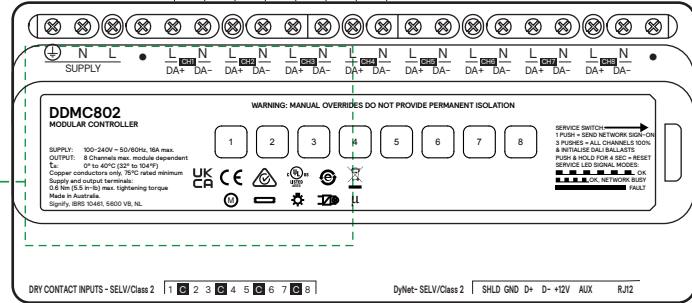

DRY CONTACT INPUTS  
SELV/Class 2 (UL)  
RS-485 DyNet/DMX512 Rx  
12 V = 200 mA

DDMC802



DGLM402  
4 x 2 A  
Forward-phase  
dimmer module

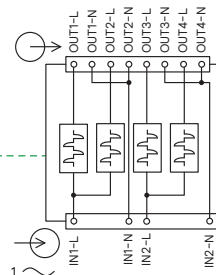

100-240 V ~  
16 A

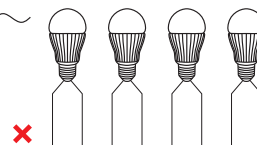

10+ AWG  
≤ 5 mm<sup>2</sup>

5.5 Lb-in  
0.6 Nm

Load Type	Output Ratings Per Channel
Incandescent	2 A, 120 / 230 V ~
Magnetic with Halogen	2 A, 120 / 230 V ~
Electronic Driver*	2 A, 120 / 230 V ~

\*can be limited by load capacitance  
Apply de-rating for electronic and LED loads.

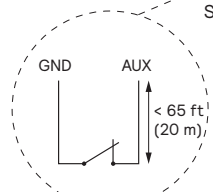
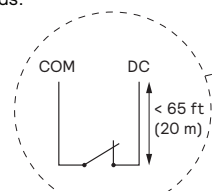
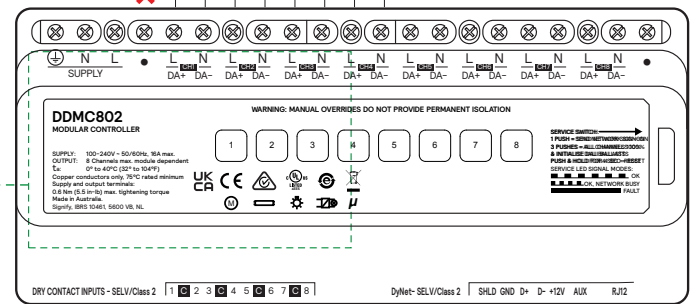

DRY CONTACT INPUTS  
SELV/Class 2 (UL)  
RS-485 DyNet/DMX512 Rx  
12 V = 200 mA

# Device wiring

## Gateways

### DDNG485

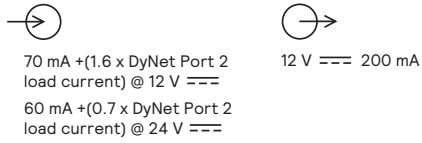
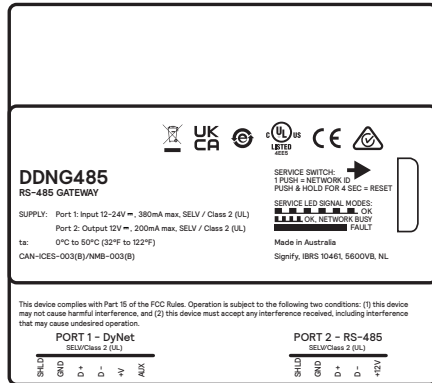

SELV/Class 2 (UL)

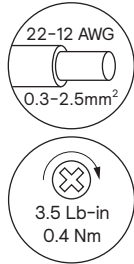
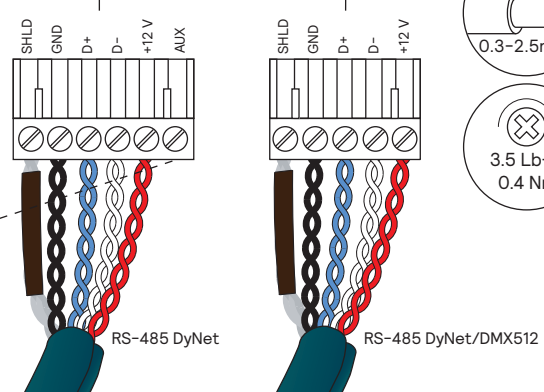
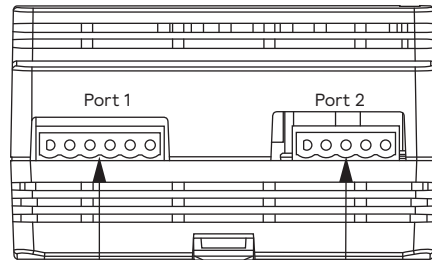
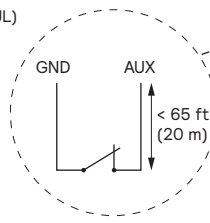

## PDEG

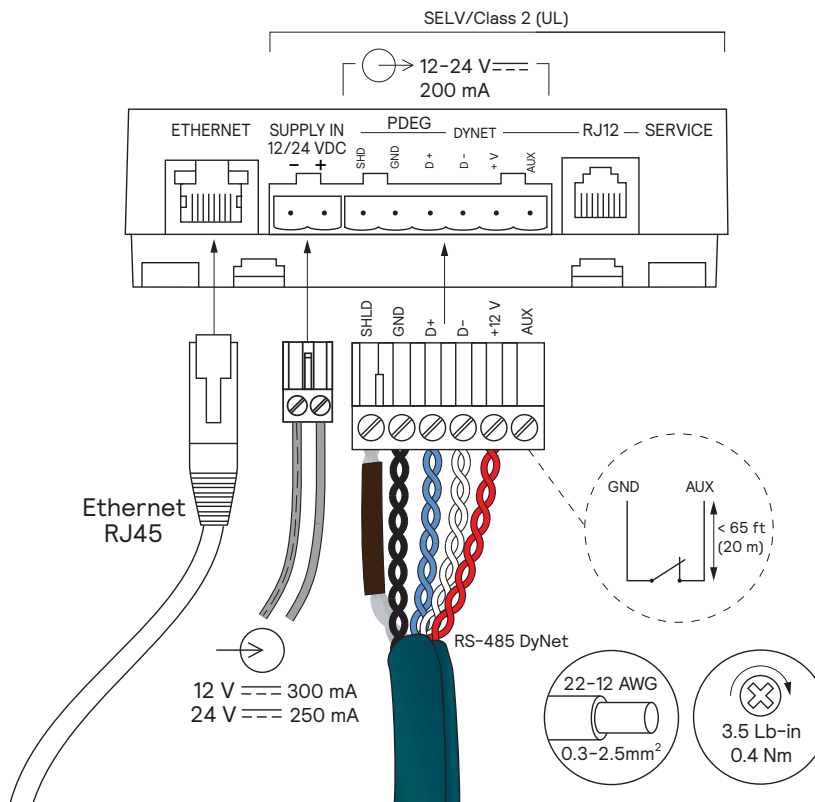

## Device wiring

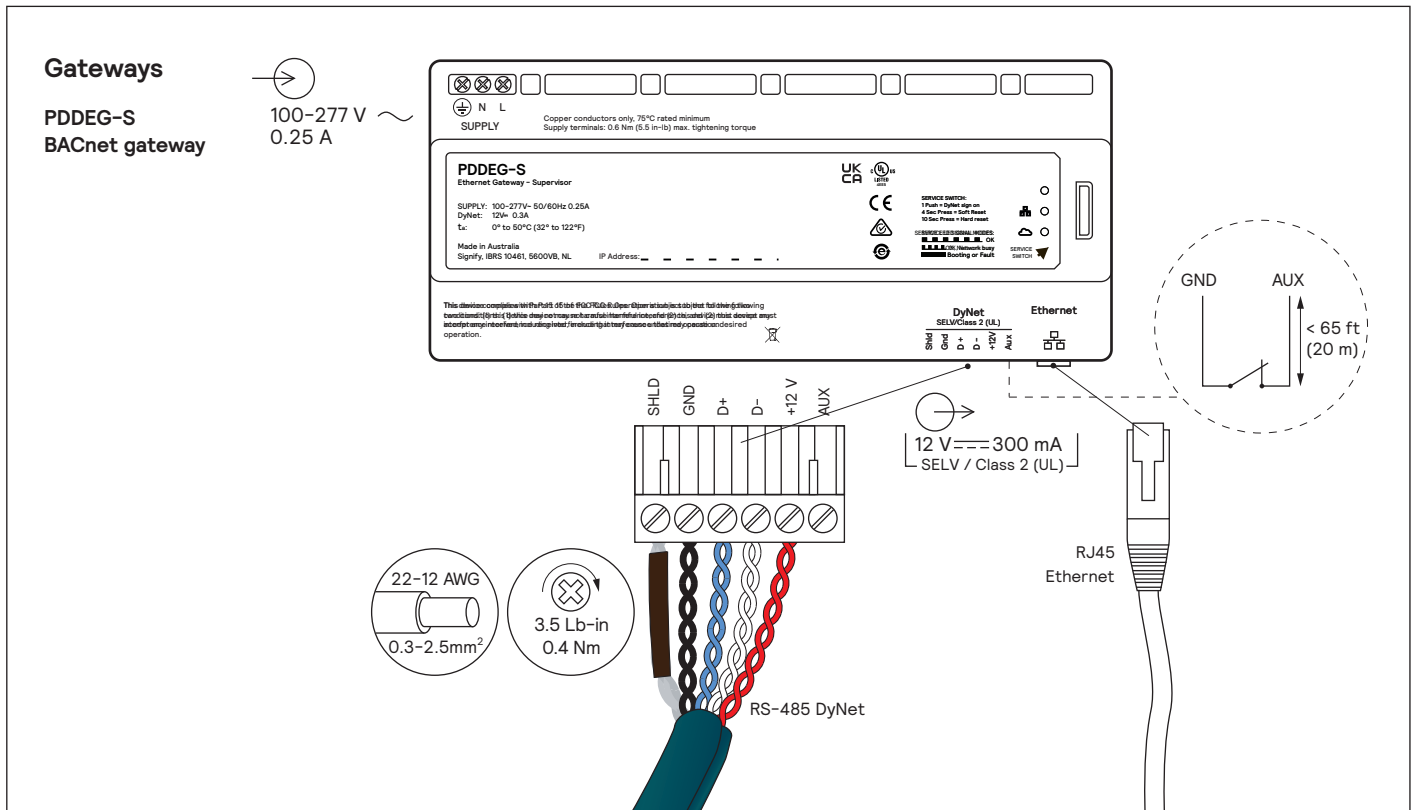

## RS-485 connections to field devices

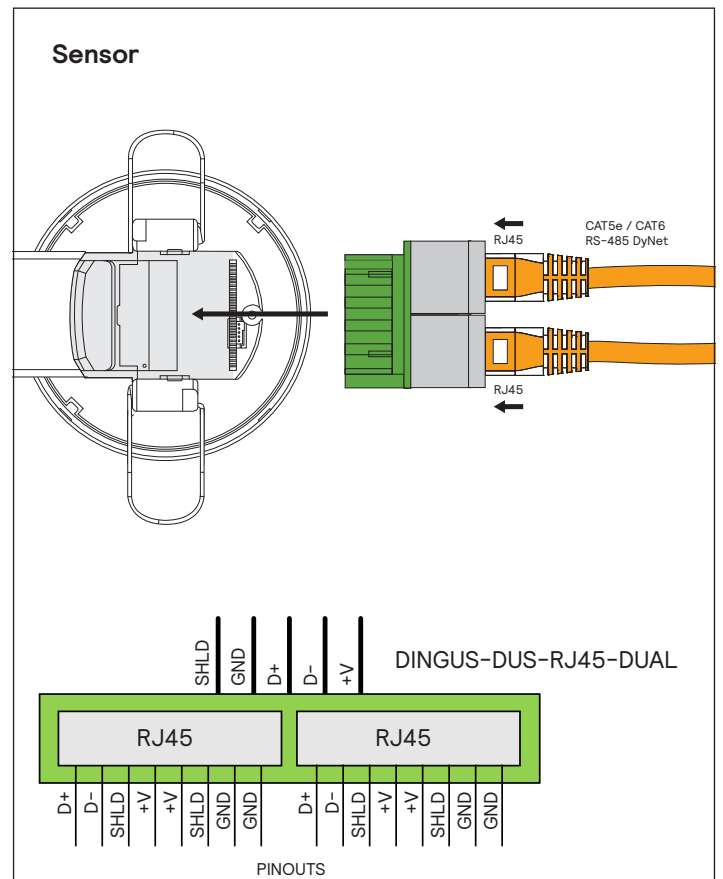
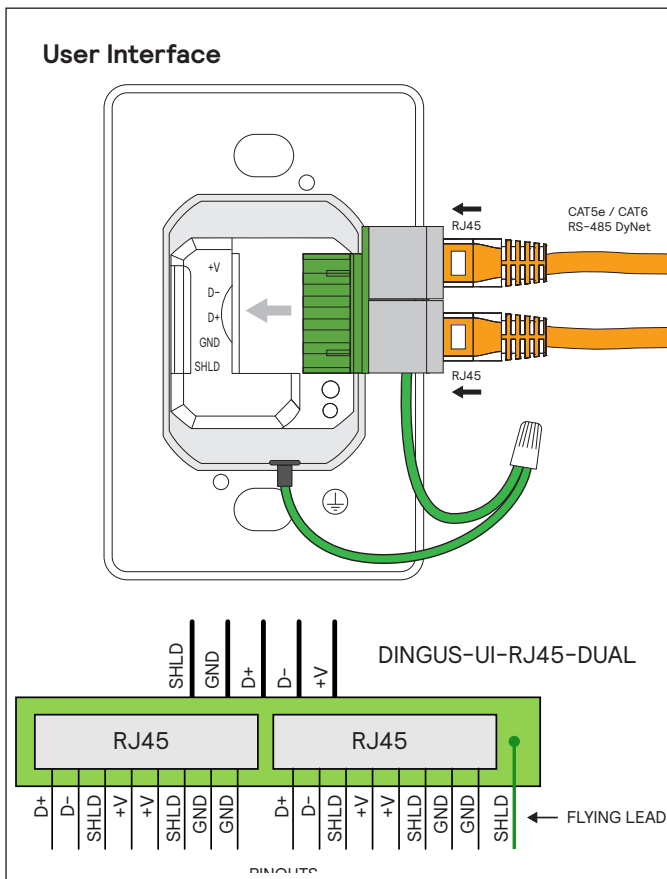

## Lighting control network topologies

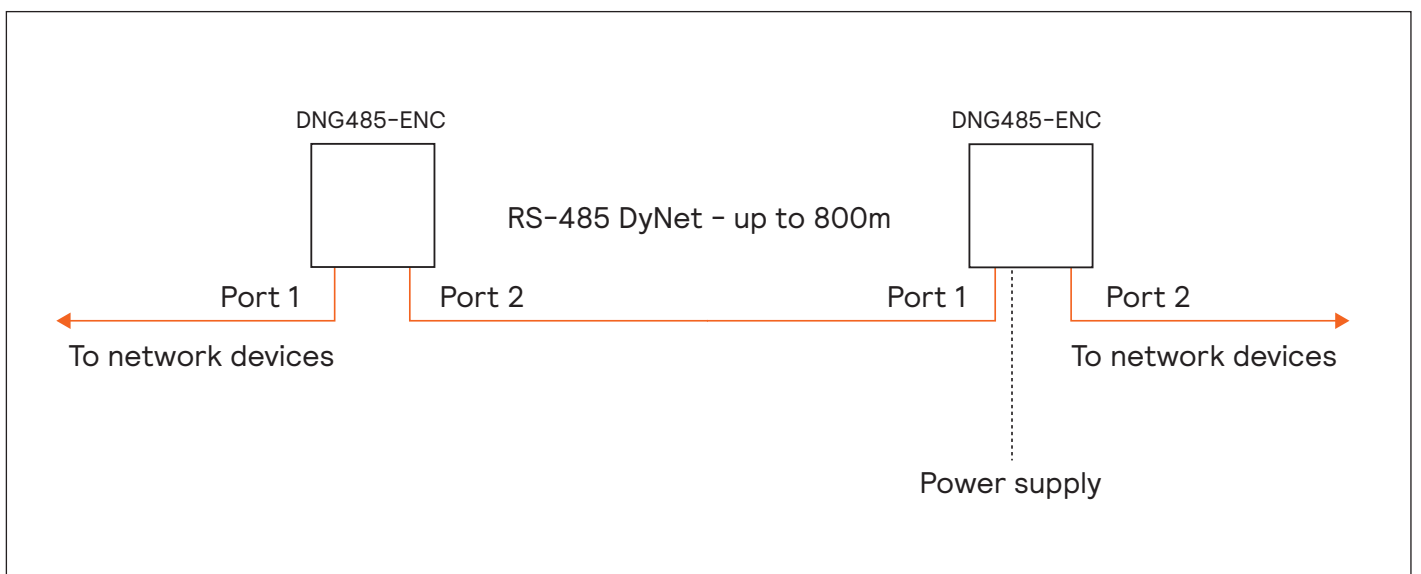
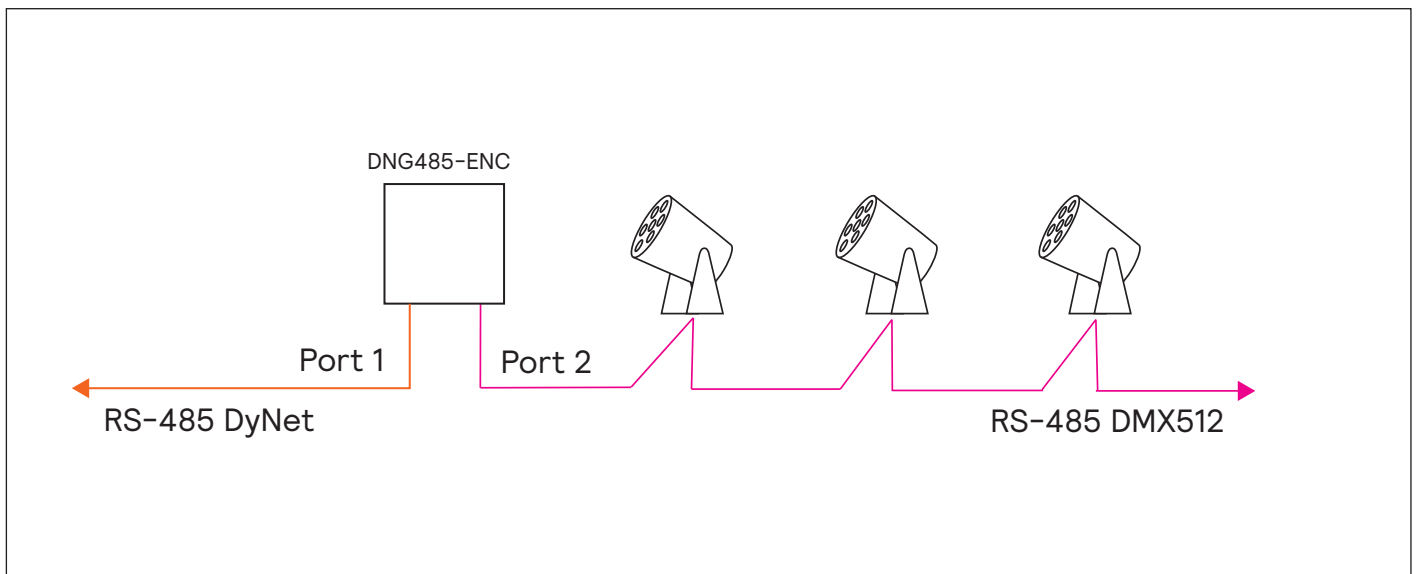
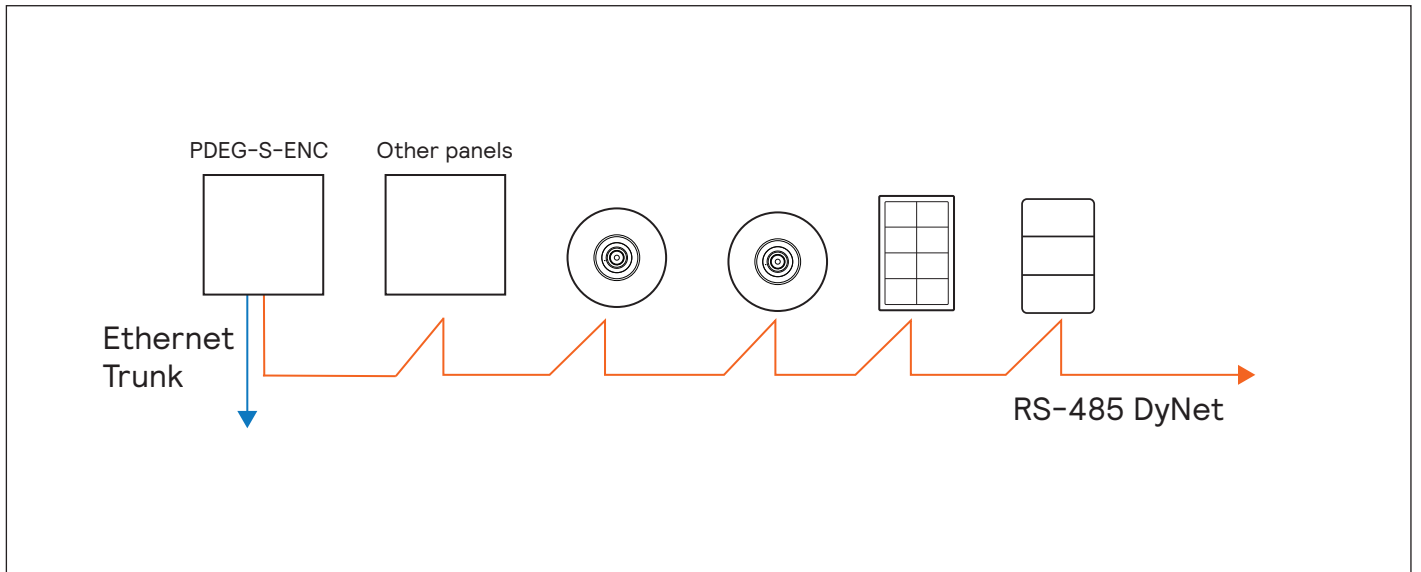

## Load schedule

Channel	Description	Channel type	Phase	Wattage	Voltage	Breaker
1						
2						
3						
4						
5						
6						
7						
8						
9						
10						
11						
12						
13						
14						
15						
16						
17						
18						
19						
20						
21						
22						
23						
24						

⚠ The site specific installation manual shall include detailed information for properly locating the components of a system in a given space. This information shall include, as applicable, drawings depicting examples of correct installations, as well as examples of unacceptable installations that may pose a risk of UV overexposure (e.g. installation at inappropriate heights, locations or orientations, open sightlines between the radiation source and exposed upper floors, stairs or walkways, etc.).

⚠ Only install sensors supplied with the system. Ensure that only the required number of sensors are installed for your space. The remainder can be used as spares.

⚠ Refer to System Builder user guide for system setup and operation.

⚠ This Class A digital apparatus complies with Canadian ICES-003.

⚠ Warning - This is a Class A product. In a domestic environment this product may cause radio interference in which case the user may be required to take adequate measures.