

PATPE

Antumbra Touch EU

signify
Dynalite

Specification Sheet

User Interfaces > Glass Look



Contemporary smooth glass panels with capacitive touch technology.

The Antumbra Touch user interface has a smooth glass finish with capacitive touch technology to detect button presses. It also incorporates the latest in field effect technology to sense a person's presence.

The PATPE range is suitable for, but not limited to, European, Middle Eastern, African, and Asian markets.

Key Features

- **Field effect proximity detection** - The user interface detects an approaching user and 'wakes up', initiating a wall-wash lighting effect to encourage interaction (mounting plate must be grounded to avoid false triggering from nearby ungrounded metal objects).
- **Capacitive touch technology** - Smooth glass finish detects the presence of a finger and triggers a button press action.
- **Supplied as two components** - The Application Module contains buttons, rim, base, and mounting plate, which can be mixed and matched to suit décor. The Communication Module contains all of the logical and network functions and is pre-programmed off-site, allowing commissioning to commence prior to finish options being finalised.
- **Hidden sensory inputs** - Built-in temperature and humidity sensors automatically adjust air conditioning when integrated into the system.
- **Multiple language and icon labelling** - Button labelling language choices include English, Chinese, and Arabic. A library of common icons transcends language barriers, which is particularly useful in hospitality applications.
- **Décor-matching options** - Rims are available in aluminium, black, chrome and white. Fascia finishes include black, silver and white.
- **64-channel DMX Tx support** - Can be factory-set to DMX instead of DyNet, to communicate directly with DMX512 fixtures.

Dimensions

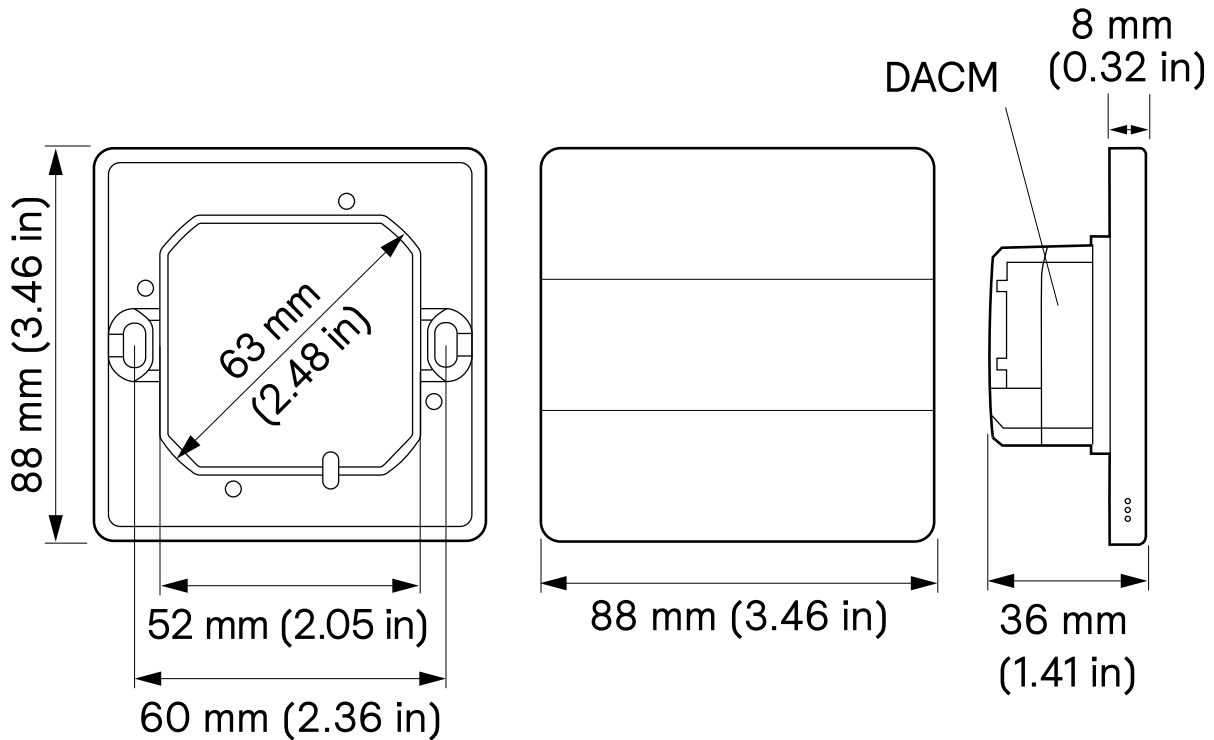

Specifications

Electrical	
Supply Type	DyNet
Supply Voltage	12–24 VDC (SELV/Class 2)
Supply Current	40 mA @ 12 VDC 25 mA @ 24 VDC
IEC Overvoltage Category	II

Application Module	
User Controls	6 x software-configurable buttons
Indicators	White indicator LED on each button White wall-wash backlight
Temperature Sensor Range	5° to 40°C (41° to 104°F)
Temperature Sensor Accuracy	± 0.5°C (± 0.9°F)
Field Effect Detection Range	approx. 15 cm (6 in)

Communication Module	
Serial Ports	1 x RS-485
Supported Protocols	DyNet DMX Tx
DMX Tx Channels	64
User Controls	1 x service switch
Indicators	1 x service LED

Available Finishes



Black



Silver



White



Aluminium



Black

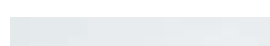

Chrome



White

Physical	
Dimensions	88 x 88 x 36 mm (3.46 x 3.46 x 1.42 in) (Fully assembled)
Packed Weight	Application module: 0.15 kg (0.33 lb) Communication module: 0.12 kg (0.25 lb)
Serial Ports	1 x 5-way pluggable screw terminal
Serial Port Conductor Size	0.3–2.5 mm² (#22–12 AWG)

Environment	
Operating Temperature	–5° to 50°C ambient (23° to 122°F)
Storage/Transport Temperature	–25° to 60°C ambient (–13° to 140°F)
Relative Humidity	≤90% non-condensing
IEC Pollution Degree	II
Installation Note	Indoor installation only

Compliance	
Certifications	CE, RCM, FCC, ISED, UKCA
Sustainability	RoHS
IP Rating	IP22



Antumbra Touch EU Assembly

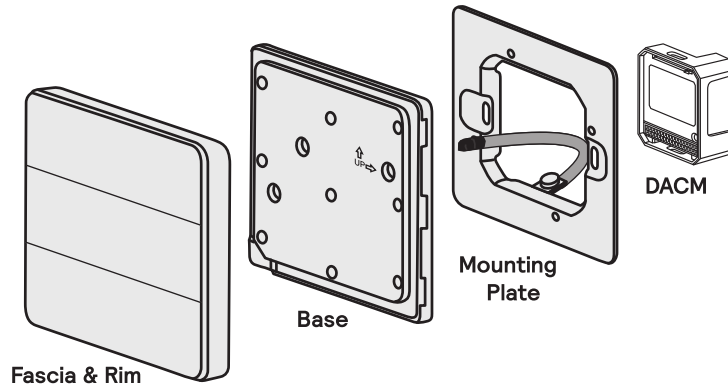

Ordering Codes

Application Module Ordering Codes

The Application Module contains the fascia, rim, base and mounting plate. The fascia and rim are available in the range of finishes shown below. The base contains all the sensors and LED indicators. Sensitive components are enclosed by a rubber envelope to give an IP22 rating, allowing installation in high-condensation environments such as bathrooms.

A metal mounting plate attaches the Antumbra panel securely to the wall, ensuring stable, reliable operation.

PATPE-WC-X

B = Black

S = Silver

W = White

A = Aluminium

B = Black

C = Chrome

W = White

L = Labelling

X = No Labelling

Communication Module

The Communication Module is compatible with all interfaces across the Antumbra series, and can be ordered, programmed, installed, wired, and tested without the Application Module attached.

This allows the commissioning process to begin before the final finish options have been chosen, or during construction, and protects the Application Module from damage until the site is ready for occupancy.



Product		12NC
DACM-DyNet	DyNet communication module	913703072809

Accessory		12NC
D-DACM-DINGUS-RJ12-QTY10	Dual RJ12 connector with earth wire - pack of 10	913703255209
D-DACM-DINGUS-RJ45-QTY10	Dual RJ45 connector with earth wire - pack of 10	913703254809