



©ignify
Dynalite

Creating smart buildings with intelligent controls

The Dynalite system explained

Lighting Controls



Contents

- What is lighting control? 3
- The value of networked lighting control 3
- System Capabilities 4
 - The intelligent control system at work 4
- Lighting control groups 6
 - Lighting management 7
 - Energy management 7
 - Regulatory compliance 7
 - Occupant comfort 7
 - Integrated operation 7
 - Environmental monitoring 7
- Preset lighting scenes 8
- What is DyNet? 9
- How the system works 10
- Lighting control technologies 12
- Network components 16
 - User Interfaces 16
 - Sensors 17
 - Dry Contact Interfaces 17
 - Load Controllers 19
 - Relay Controllers 19
 - Integrations 19
 - Network Devices 19
 - System Builder 20
 - System Manager 21
 - Dynalite Cloud Platform 21
- Why choose Dynalite 22

What is lighting control?

The fundamental purpose of lighting control is to provide quality light when and where it is needed.

Since the discovery of fire, humans have searched for ways to harness the power of light to support their daily activities. The invention of the lightbulb greatly expanded artificial lighting applications and, more recently, lighting has entered the digital age with the universal adoption of LED lighting and networked control.

In its most basic form, a simple light switch delivers manual on/off control. This type of lighting control typically uses a standalone circuit for a single room in isolation from other parts of the building. Traditional switched circuits offer limited features, can become quite expensive and complex when trying to scale up, and rely on occupants to turn the lighting off when not needed. Also, there is no way to coordinate lighting across multiple areas to improve occupant experience or building efficiency.

The value of networked lighting control

A modern networked system can provide local, centralised, and remote lighting control throughout a building or campus. The system can automate changes to brightness and colour across multiple lighting groups to create visually appealing spaces that are tailored to the needs of occupants.

Networked sensors and other control devices enable the system to respond intelligently to changing conditions, such as turning off lights in unoccupied spaces to conserve energy.

The Dynalite networked lighting system harnesses the power of connectivity to create value beyond illumination. It can collect and share data, adapt intuitively to the evolving needs of users, reduce energy usage, and work together with a range of third-party integrations including building management and HVAC systems.

Simple switched lighting circuit

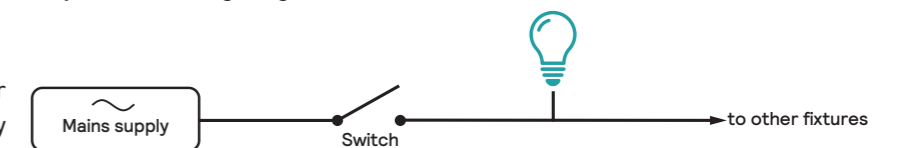

Network control lighting circuit

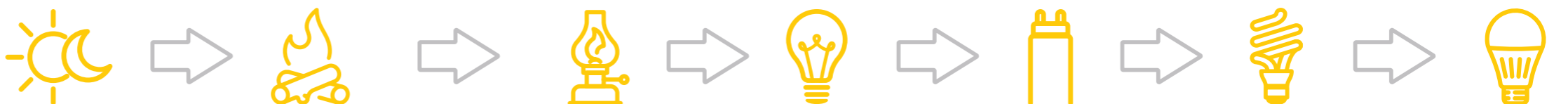
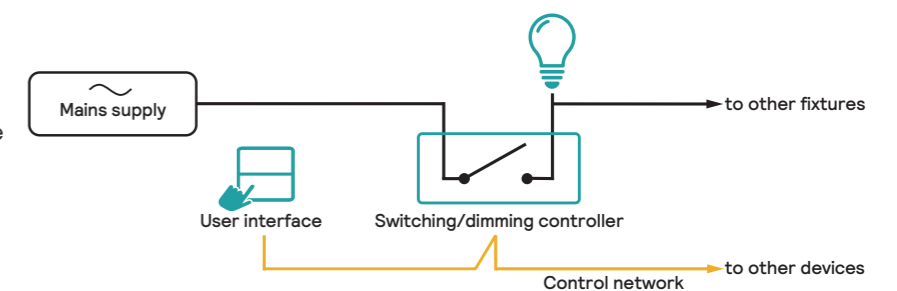

System Capabilities

The intelligent control system at work

Rooftop

The pool and entertainment lighting is easily controlled by networked button panels. Different lighting scenes and colors can be preprogrammed to produce the desired mood for the activity or event.

Restaurant

Custom lighting scenes can contribute to a truly unique dining experience.

The system supports all lamp types and can automatically adjust lighting, blinds, and awnings in response to scheduled events or light level sensor inputs.

Touchscreens and apps provide multiple points of control to set the perfect scene.

Retail Shops

Enable your retail location to shine in the best possible light. Create a welcoming atmosphere so customers can safely navigate around the shop and find what they need.

Set a brand-specific tone for a memorable customer experience that encourages spending, loyalty, and repeat visits.

Car Park

The car park is often the first place in a building that people experience, and should feel welcoming and safe.

The Dyalite system optimises lighting and energy usage while still enhancing comfort and safety.

Gardens

External garden and pathway lighting improves the aesthetics outside and increases safety at night.

Hotel rooms

Guests can enjoy total control at their fingertips, while building owners save money on their energy bills. Our home automation solutions are designed to seamlessly integrate with a range of services within hotels, apartments, and standalone dwellings, including lighting, security, heating, ventilation, air conditioning, home theatre, audio, blinds, and curtains.

Offices

A clever combination of scheduling and motion sensing can effectively reduce running costs while still providing the right level of lighting for staff to carry out their duties. Centralised monitoring and control offers additional benefits for fine tuning system responses.

Gymnasium

Create versatile lighting scenes to enhance safety and help members to feel energised or relaxed for various activities.

Architectural Features

Dyalite, in conjunction with Color Kinetics, can create memorable dynamic lighting effects to enhance gardens, courtyards, and building facades, leaving visitors with a positive and lasting impression.

“ Manage lighting, climate, and automation across an entire building or multiple tenancies – from individual hotel rooms to expansive public spaces. One system, comprehensive control. ”

Lighting Control groups

A strength of the Dyalite system is its ability to control different lighting groups, such as, a single light, a room, a whole floor, or an entire building with one simple message on the control network.

The system can even detect occupancy in a room and keep the lights on in the associated corridors and lobby, ensuring there is always a lit path to an exit. This impressive feat is achieved by grouping the lighting fixtures into lighting channels and areas using our System Builder software. By communicating with these groups (areas), the Dyalite system reduces the number of messages flowing over the

network to achieve a seamless and coordinated response. The office floor plan below shows how various lighting fixtures can be grouped into distinct areas.

Control messages triggered by occupants pressing a button or being detected by sensor simply address these areas to change the lighting outputs. The system can address up to 65,500 areas on a single network.

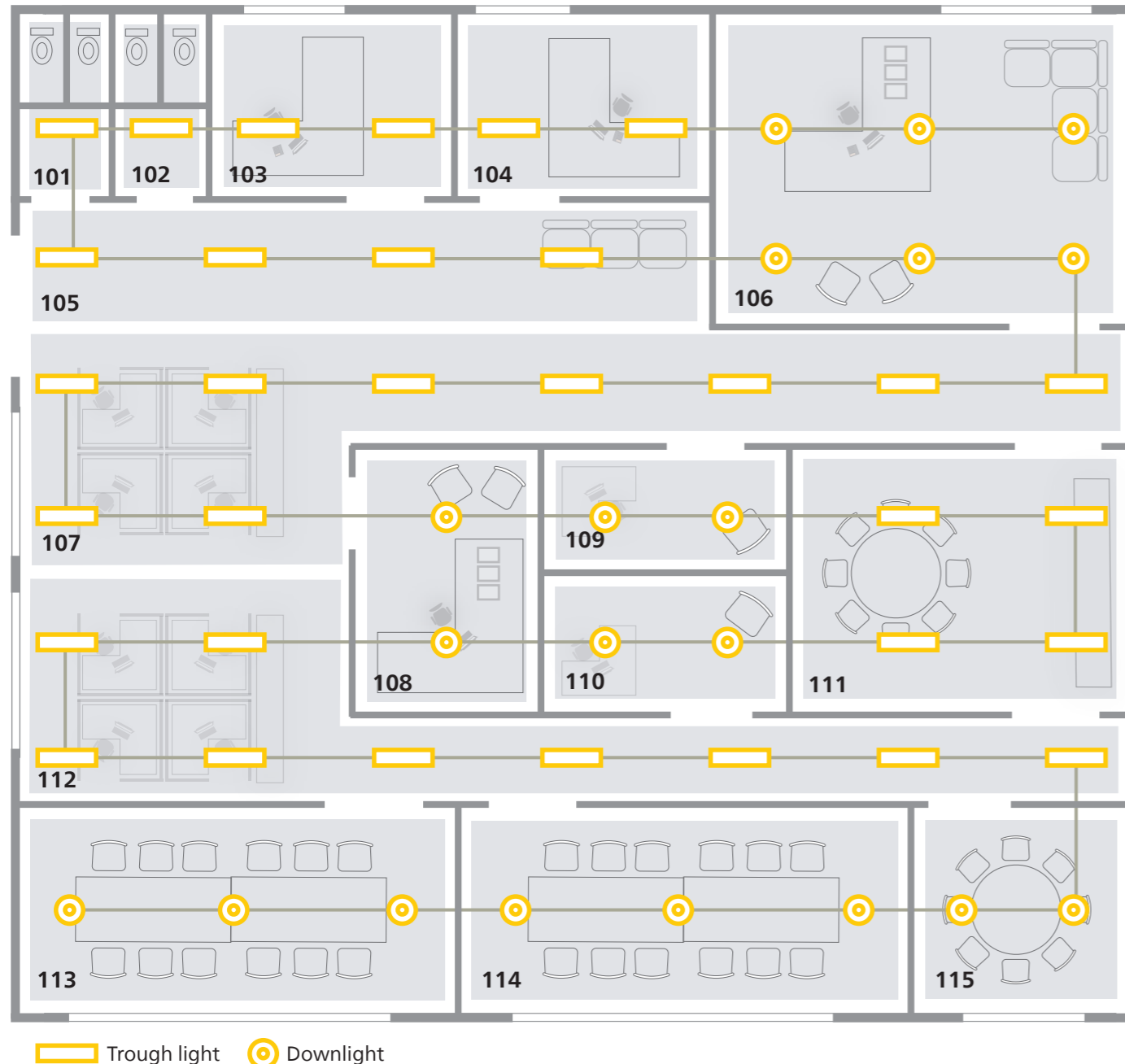

Lighting management

At its core, the Dyalite system is a lighting management platform. It enables users to create and schedule different lighting scenes to suit a variety of occasions, sort luminaires into functional groups, and reassign those luminaires to different areas as the needs of a space change.



Energy management

The Dyalite system reduces energy consumption and lowers a building's operating costs. A selection of tools such as daylight harvesting, occupancy detection, dimming, and scheduling work in harmony to eliminate unnecessary power usage and support our customers' sustainability objectives without compromising occupant comfort.



Regulatory compliance

Dyalite products are designed and tested for compliance to a range of international regulatory standards including RCM, CE, UL/cUL, UKCA, REACH, and RoHS. Our systems also support adherence to health and wellness standards such as BREEAM, LEED, and WELL. In addition, System Manager enables facility managers to easily run mandatory testing to ensure the proper functioning of emergency lighting in line with local regulations.



Occupant comfort

Bespoke lighting scenes create the right ambience for any activity. Lighting levels can adapt dynamically to suit the time of day and support circadian health to enhance the well-being and safety of building occupants. Integration with third-party systems such as HVAC and audio-visual creates a simple yet sophisticated user experience.



Integrated operation

The Dyalite system seamlessly integrates with a range of third-party systems to optimise building efficiency and enhance occupant comfort. For example, our sensors may be used to return the air conditioning to standby mode when a room is unoccupied, or adjust blinds in an office building throughout the day to minimise glare. The possibilities are endless.



Environmental monitoring

A selection of motion and environmental sensors, user interfaces, and input devices provide valuable insights to fine-tune a building's energy management strategy and more. The Dyalite system makes it easy to monitor environmental conditions, analyse occupancy trends, and even report individual room occupancy statuses to your building or property management system.

Preset lighting scenes

A preset scene can change the lighting levels of all channels in an area to different values. Lighting channels can also be controlled individually or in smaller groups. A simple button press or an action from a sensor sends a network message to the load controller to change the lighting levels. For example, “Area 2, channel 1 go to 100% over 5 seconds” or “Area 2, recall preset 1 using a fade time of 2 minutes”.

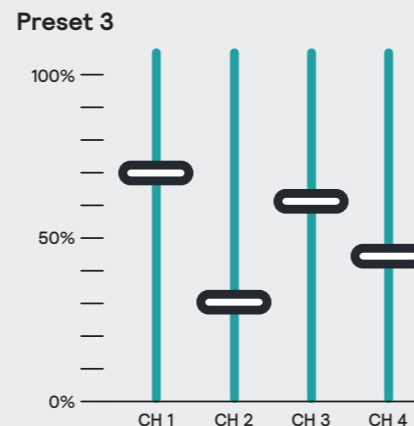
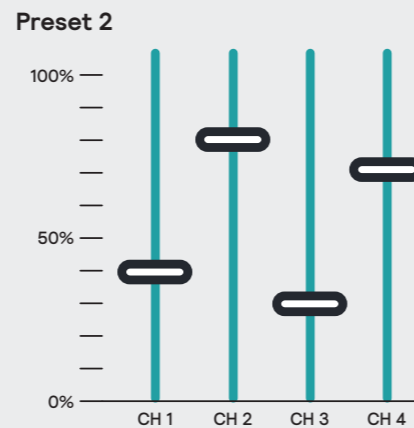
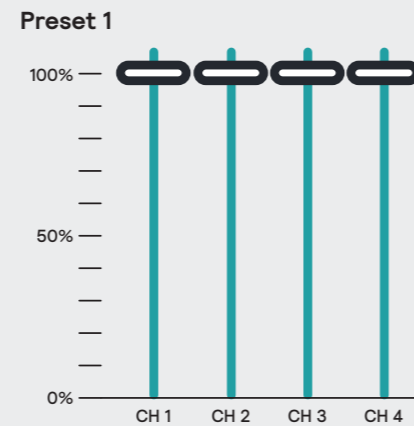

What is DyNet?

The heart of the Dyalite network architecture is the DyNet protocol. Based on the RS-485 open industry standard, DyNet simultaneously allows for flexible installations while delivering powerful network functionality.

DyNet enables individual addressing of Dyalite devices for commissioning, and area-based addressing for driving circuits and lighting groups or instigating changes across a hybrid mix of light fixtures, motorised window coverings, heating, ventilation, air-conditioning (HVAC), or other building services.

Every Dyalite device includes at least one DyNet port, enabling direct communication between devices. This eliminates the need for hidden third-party network accessories like mandatory network power supplies or centralised processors that rely on Ethernet or cloud connections for core functionality.

Within every Dyalite network device is a logic engine, empowering the devices to run multiple network instructions

from a single trigger or multiple conditional inputs. Area preset states can be used throughout the system to perform a variety of sophisticated sequential and conditional logic tasks.

DyNet uses a distributed intelligence architecture for immense scalability, enabling all devices to directly communicate with each other, removing any risk of broad failures greater than a single device. A network message from any device can be used to initiate changes across an entire project, potentially addressing up to 16.5 million devices. This makes the DyNet protocol one of the most efficient in the lighting control market.

Details of the DyNet open protocol and network messages are available from www.dyalite.com/technical.



“ The DyNet protocol is equipped to handle projects of any application or size. ”

How the system works

The diagram below illustrates a typical layout of luminaires and physical devices. Occupants simply interact with the sensors or user interfaces to see the resulting lighting effect.

The system consists of a unified codebase, multi-protocol support, robust hardware, and adaptable network topology, providing unmatched versatility and scalability. Our commitment to simplicity and reliability ensures that our network components work together in harmony.

Our industry-leading lighting control system enables building services such as lighting, HVAC, AV systems, and window coverings to respond intelligently to sensors, user interfaces, and other network events. Software and hardware work in concert to deliver the latest proven and secure lighting technologies with flexible load controller outputs (including switching, phase-cut dimming, PWM, 1-10V, DALI, and DMX512), and a range of input devices, and integrations to third-party building systems.

Our modular architecture uses a consistent design that is fully scalable, and quick to install and commission. System components are application-agnostic, ensuring that control features are applicable to a wide range of lighting and energy management scenarios.

Data collected through sensors and other devices empowers building owners and managers with the insights needed to optimise operations, maximising efficiency and savings without sacrificing occupant comfort. Dynalite systems are trusted in hospitals, hotels, offices, shopping centres, airports, and stadiums across the world.

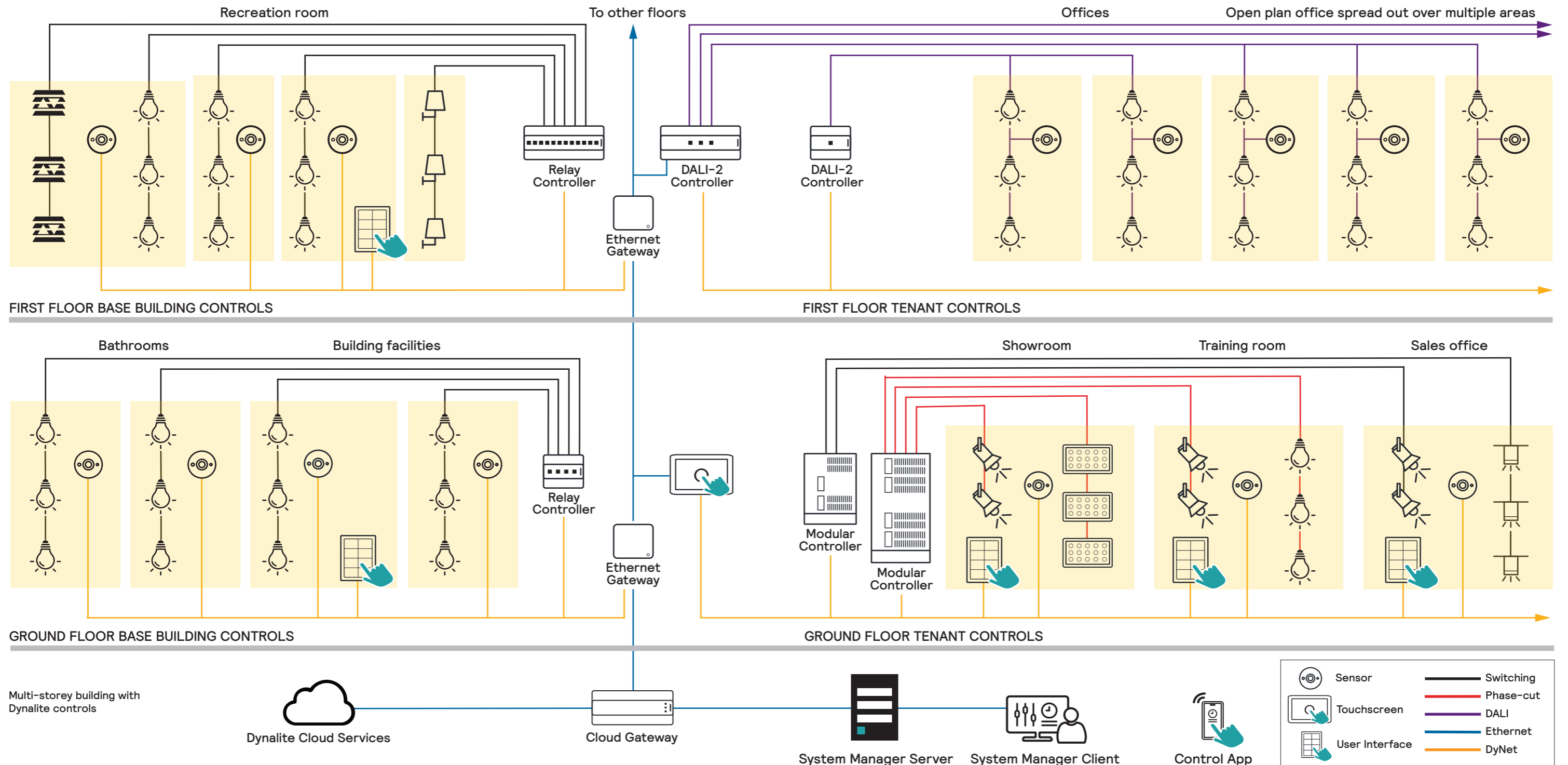

Lighting control technologies

The following three pages briefly describe commonly used lighting control technologies to help you build a background knowledge of network lighting control systems.

Switching

ON/OFF Switching is the simplest and most common method of lighting control. Relay controllers with single pole, single throw relays are typically used to switch the power for lighting loads or plug loads (general purpose outlets).



Single-pole, single-throw relay for energising a circuit

Relay controllers with single pole, double throw relays are designed for controlling motor loads such as those used for automated window coverings.



Single-pole, double-throw relay for changing motor direction

Phase-cut / Power dimming

Phase-cut dimming modifies the mains supply to reduce the overall power supplied to the lamps. This is achieved by 'chopping out' a varying section of each cycle depending on the amount of dimming required. This method requires constant measurement and detection of the mains supply.

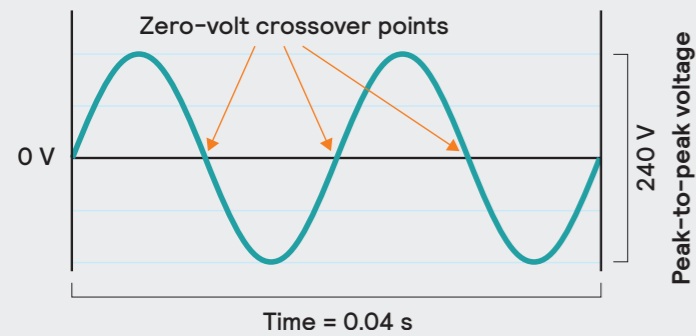

Example of ideal power supply

The mains supply changes constantly and is commonly subject to noise, frequency shift, surges, and brownouts. A quality lighting control solution monitors the mains supply and compensates for inconsistencies to ensure a smooth and consistent light level.

Most critical is the zero-volt crossover point, on which the dimmer bases its calculations and timing to drive the output channel. There are two methods of phase-cut dimming – leading-edge and trailing-edge – and care must be taken to match the control type to the lamp requirements.

Leading-edge control

For leading-edge dimming, the supply is stopped from the zero-volt crossover point until the correct time when the power for the desired dimming level is reached. At this point, the supply is switched back on and allowed to flow.

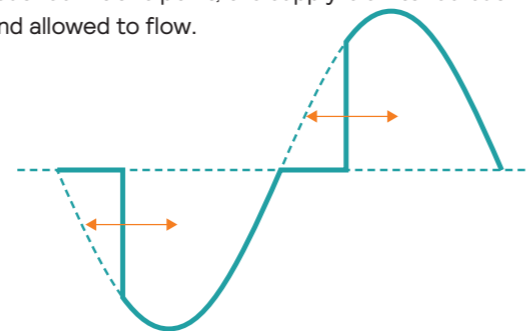

Trailing-edge control

For trailing-edge dimming, the supply is allowed to flow through from the zero-volt crossover point until the correct power is reached for the desired dimming level. At this point, the supply is switched off.

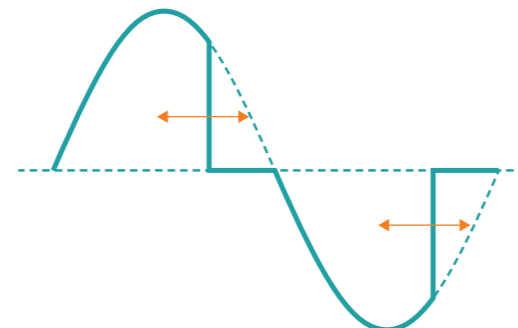

“ Dynalite provides reliable and energy-efficient networked lighting control solutions that integrate advanced functionality with aesthetic and sustainable lighting. ”

Signal dimming

Some lamps depend on an external transformer or driver to modify the supply to set the required brightness. Each driver receives instructions from the lighting control system to modify the dimming level.

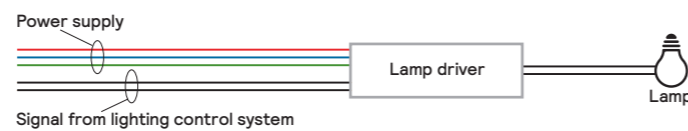

0-10 Volt

For 0-10 V analog lighting control systems, the load controller transmits a low voltage signal: 0 volts equates to 0% lighting output; 10 volts equates to 100% output. All fixtures within one lighting group respond to this dimming instruction at the same time. There is no error detection and fixtures accept any voltage on the control line as a valid signal, so the lighting control system may not be able to turn lamps off through the control line alone. Such cases may require a parallel relay that completely cuts power to the fixtures when they should be off.

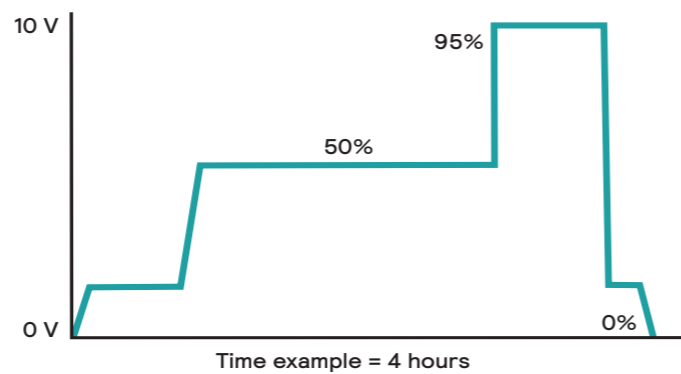

Lighting control system varies between 0-10 V to adjust the output level.

DALI

For a Digital Addressable Lighting Interface control system, the load controller transmits a more sophisticated digital signal to the lamp drivers over the DALI network. DALI drivers include built-in processors that support multiple levels of addressing and more advanced feedback functions.

DALI can operate in two distinct modes: DALI Broadcast and DALI Addressing.

With DALI Broadcast, all lamps within one lighting group

will respond at the same time. All Dynalite DALI controllers are able to perform this function. In DALI broadcast mode, lamps cannot perform any feedback or additional DALI addressing functions.

By comparison, DALI Addressing allows individual lamps and defined groups to be controlled on the same physical network. DALI Addressing is able to support many advanced features including lamp status and emergency lighting testing.

DALI protocol

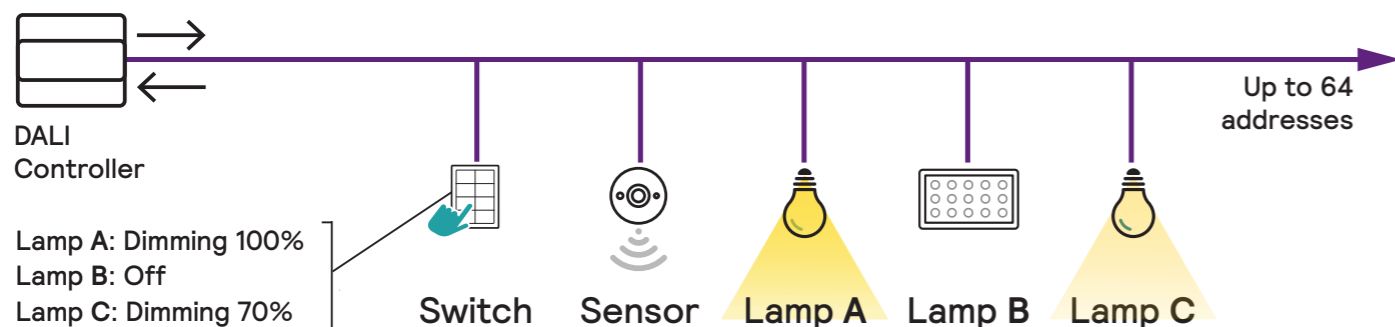

DMX512

For Digital Multiplex systems, network gateways are used to transmit a digital signal to the lamps. DMX is a fast, high-traffic protocol that excels at smooth ramping and dimming performance.

DMX512 supports up to 512 channels on a single bus. The controller/gateway continually transmits a stream of packets on each channel with a basic 0-255 value

regardless of the target device type. Motorised lighting, smoke machines, and even water features support DMX control.

DMX512 does not include automatic error checking, and may be prone to interference or false triggering. It should not be trusted for hazardous applications such as pyrotechnics or motorised theatrical rigging.

DMX512 protocol

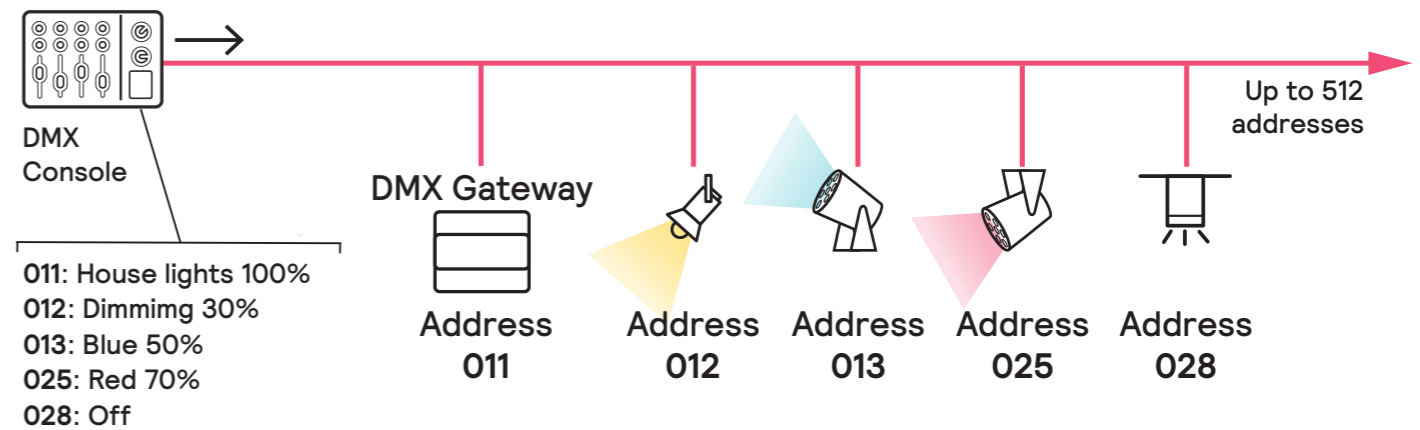

PWM dimming

Pulse Width Modulation uses rapid on/off switching of the DC output to control LED lamp brightness. The extent of the dimming is regulated by the ratio of 'on' and 'off' phases. The switching occurs faster than the human eye can possibly detect, resulting in smooth dimming.

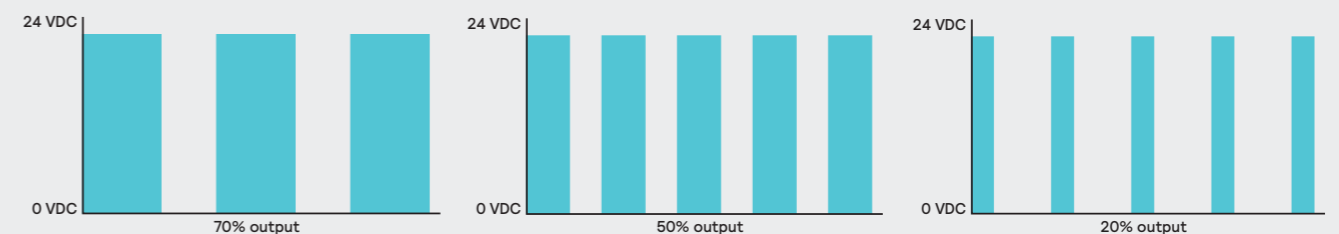

Network Components

“ Dynalite has a complete range of control products and integration gateways to accommodate any lighting load and building control application. All Dynalite networked products are tested to verify reliable operation and interoperability throughout the system. ”

User interfaces

Networked interfaces communicate directly with load controllers and other devices on the network. They have built-in proximity, temperature, and humidity sensors and can perform a wide range of functions such as recalling presets, switching, dimming, colour control, room join, panel disable, and controlling integrated services such as audio-visual systems, blind/curtain and fan motors, or HVAC.

Buttons can be programmed to perform several functions from a single press. They can also dynamically change their function to provide time-dependent responses.

Right: Dynalite Touch Screen (PDTS) and Revolution Display (PDRDE). Below: from left to right, Antumbra Display, Antumbra Button, and Revolution in the EU (rectangular) and NA (square) formats.

User interfaces are available in a broad spectrum of finishes, style options, and button configurations. All buttons have their own individual LED indicator and support engraving to identify their

functionality. User interface options further include touchscreens with customisable menus, network gateway web pages, and software applications for PCs, tablets, and smartphones.

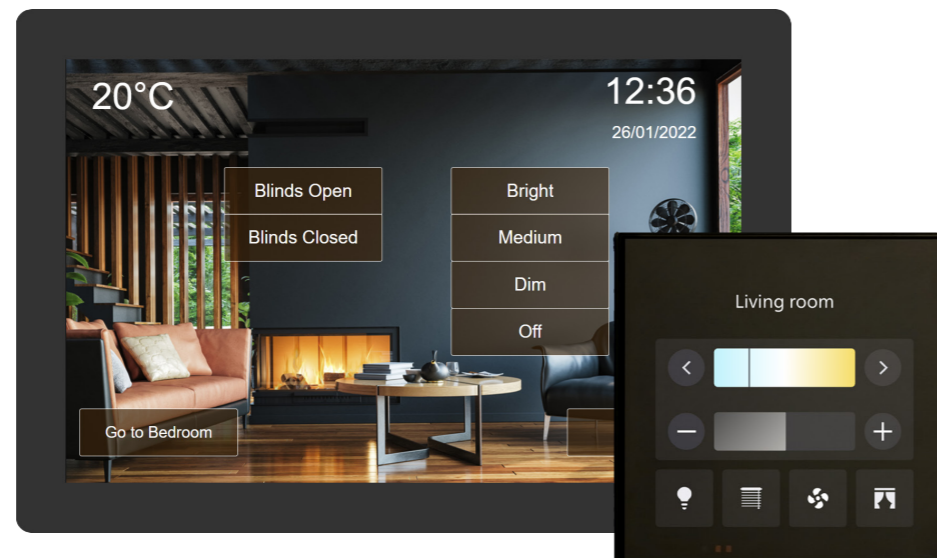

Sensors

All network sensors can manage occupancy detection and light level measurement at the same time. The sensors communicate with other devices on the network and can receive instructions over the network to adjust their behaviour. The sensor range includes different mounting options, ultrasonic operation, IR-receive capability, plus 30°, 90°, or 360° occupancy detection.

After a period of inactivity, the sensor can instruct the lighting to enter a grace period before turning off the lights in an unoccupied area. This timeout period can be easily changed depending on the level of activity, or for different times of the day, week, or year. For example, a shorter timeout period can be set during holiday periods.

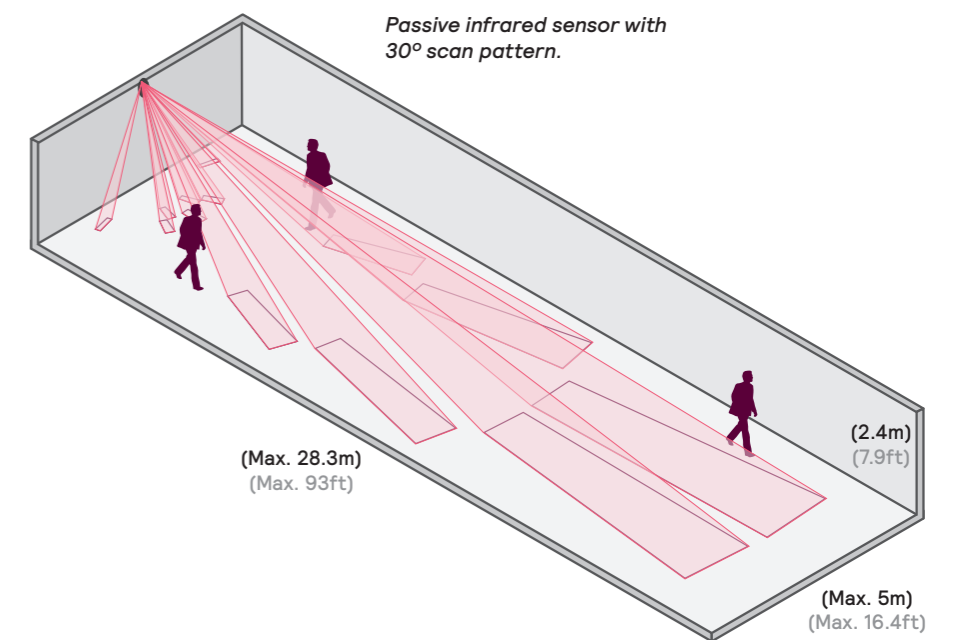

From left: DUS90CS, DNS360LB-CS-PIR-DyNet and DNS360LB-CR-PIR-DyNet ceiling mounted sensors.

Dry Contact Interfaces

Dynalite dry contact interfaces provide low-level integration between DyNet and third-party systems for simple relay-style switching to trigger a task, event, or preset. Dry contact inputs can come from a variety of sources, ranging from magnetic door

contact switches or dedicated button keypads to third-party sensors or fire/security alarms. Dry contact interfaces can be used with the DyNet or DALI network and can be connected to multiple switches and devices.

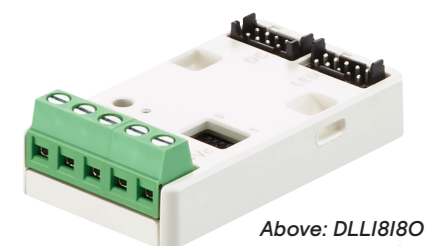

Above: DLL18180 dry contact interface.





Load Controllers

Load controllers do the heavy lifting in the control system. They receive instructions from the network and adjust their controlled outputs as required. They contain all the elements – power supply, network ports, output circuits, and the microprocessor management – needed to operate the lighting groups for which they are responsible. All channel naming information, channel addressing, area addressing, and channel scene levels are stored within the memory of the load controller.

Dynalite has a wide range of load controllers that can be mixed and matched to support various project requirements and multiple luminaire types. The load controller range features different types of output circuits for switching, leading/trailing edge dimming, PWM dimming, DALI, and 0-10 V control. Controllers offer a range of channel capacities from 2-20A, as well as a choice of wall or DIN rail mounting options.

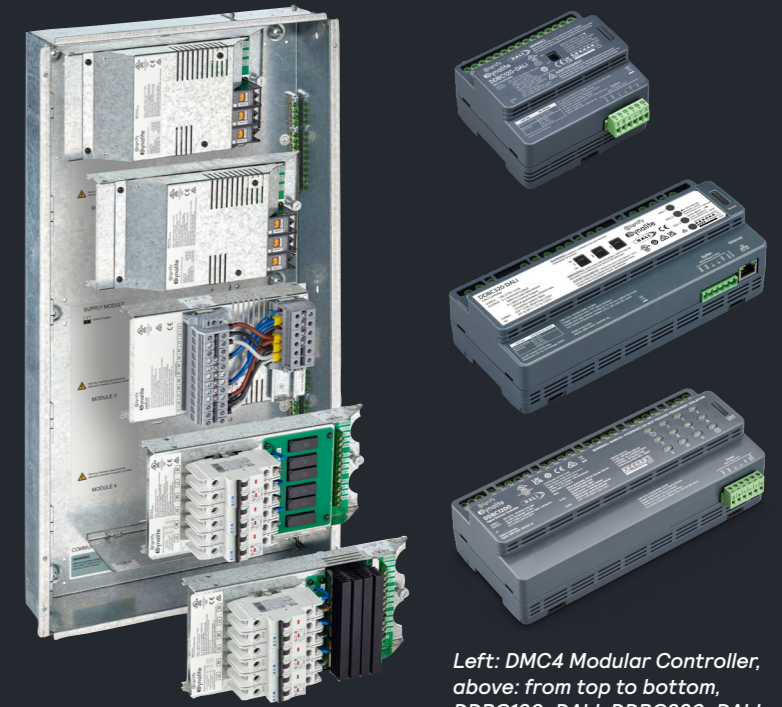

Left: DMC4 Modular Controller, above: from top to bottom, DDBC120-DALI, DDBC320-DALI, and DDBC1200.

Integrations

Dynalite offers a range of network gateways that allow multiple systems to be controlled from a single user interface. Dynalite integrates with many other protocols and services such as IT systems, access control, audio-visual, building management systems, theatrical and facade lighting, hospitality systems, direct input, HVAC systems, window coverings, Zigbee wireless, and APIs.



Above: PDDEG-S cloud/integration gateway.

Network Devices

Network devices are used to scale the control network using a resilient trunk-and-spur topology that supports the full range of user interfaces, sensors, integration gateways and load controllers. Device identification, configuration, and firmware upgrades can all be performed over the network.



Above: PDEG Ethernet gateway.

Relay Controllers

Dynalite relay controllers are built to handle the large inrush current of lighting loads. Like load controllers, they receive instructions over the network and can be used for any type of indoor circuit switching such as light switching, plug load switching, controlling blind and curtain motors, or controlling contactors for high power switching.



Above top left: DDRC1220FR-GL, above right: DDRC420FR and above DDRC810DT-GL.



“ System Builder enables you to design your Dynalite system and save the configuration to every device. No other software is required. ”

System Builder – design and commissioning software

System Builder enables direct and rapid system design and device configuration without the need for additional software, drivers, or cloud connections. Define logical areas in the building, program each control device in the project, load PDF floor plan drawings, and add virtual lamps and control devices to build comprehensive, revision-based system quotations. The designs can then be used to fast-track system commissioning.

Most building services are controlled by channel level and preset scene messages to each area. Lighting channel levels in each area can be adjusted and saved to different presets.

The software includes multiple system views, such as an overall building view, network view, areas view, and floor plan view. These enable the commissioning engineer to streamline system setup with step-by-step area-based commissioning and more sophisticated programming, as required.

System Builder’s localise-by-search feature and advanced DALI commissioning tools enable quick identification of DALI drivers and devices with flexible discovery options. Additionally, insightful DALI diagnostic tools help to rectify onsite installation issues.

As an integral part of the commissioning process, configuration data may then be exported to System Manager head-end software so that all relevant system information is made available to users.

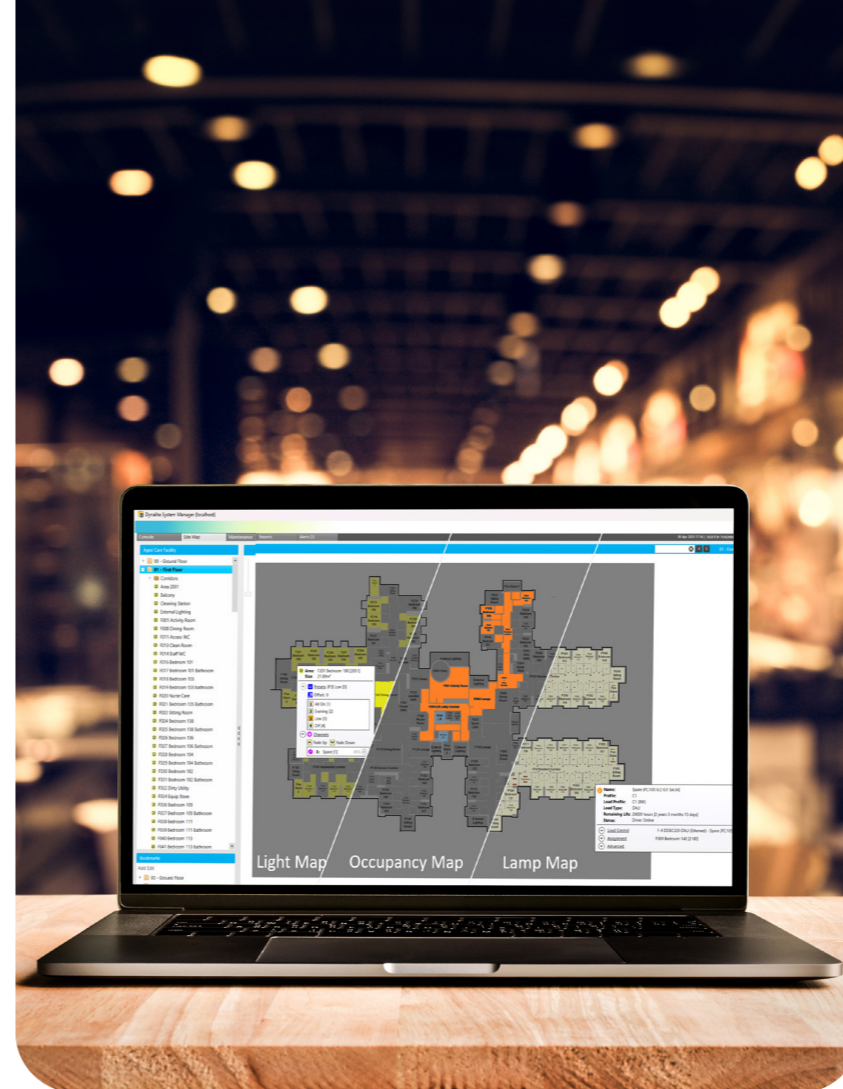

System Manager – control, monitoring, and management software

System Manager provides central control of the entire lighting system or different parts of the system.

This easy-to-use software allows multiple users to access and view the lighting control system and perform a wide range of maintenance activities such as emergency testing and DALI driver replacement. With a complete overview of a building’s lighting control system, it’s possible to navigate to any location and adjust network device functions, control area presets and channel levels, create triggers and macros, and run building maintenance programs.

System Manager is compatible with all current Dynalite products and solutions and can be used on any Dynalite project. Implementation is seamless, reusing the System Builder configuration file created during commissioning.

System Manager is designed to meet the needs and expectations of both building users and facility managers. It provides invaluable insights into system operation, highlighting areas for improvement and providing analytics for long-term strategies.

“ System Manager delivers industry leading levels of control, monitoring and management and provides the flexibility to optimise energy efficiency and maximise user comfort. ”

Dynalite Cloud



The Dynalite Cloud platform is a convenient and secure method for managing Dynalite projects remotely. The platform consists of the following elements:

- **Dynalite Cloud Portal** – browser access to your organisation’s Dynalite Cloud account.
- **Dynalite Cloud Projects** – a secure online repository for organizing and sharing lighting control project files.
- **Dynalite Cloud Connect** – remote site connectivity for diagnostics and maintenance with System Builder.

A single login to the cloud portal lets you manage your organisation’s account, users and projects. Users can be members of more than one organisation, enabling integrators to manage multiple sites on behalf of their customers. Future enhancements will include remote System Manager access, extended licensing, trusted certificate storage and transfer, and cloud-enabled integrations.

Why choose Dynalite

Dynalite is a highly specialised manufacturer whose purpose is to provide cutting edge lighting control solutions. Our achievements are recognised worldwide and Dynalite is generally the system of choice for projects involving integration with third-party equipment and large-scale applications, due to our commitment to quality and feature-rich product portfolio.

Dynalite's philosophy is to provide the best solution possible for each and every project. This is the key to our success. Our considerable ongoing investment in research and development makes it possible for us to remain at the forefront of our industry. Our position as a world leader in lighting management systems into the future is sustained through our total commitment to innovation.

We are represented around the world by distributors and dealers who are handpicked for their ability to provide the highest possible level of service.

From a stock exchange in Shanghai, to a luxury resort in Dubai, a supermarket in the UK to a shopping mall in Sweden, a smart home in São Paulo to limestone caves in New Zealand, Dynalite's innovative solutions deliver reliable, intelligent light.

Continuous improvement based on real-world challenges has enabled Dynalite to create secure automated systems that control tens of thousands of individual light fittings in high-rise buildings all around the world. Our networks are engineered to deliver instant notification of lighting issues, and our software provides real-time multi-user control and visualisation of system events. This provides the assurance necessary in applications where continuous operation is vital, such as road tunnels, data centres, or cold storage units.

Dynalite's modular product design philosophy also improves system flexibility. Through this approach, specific application requirements can be accommodated with greatly reduced lead times. As an industry leader, Dynalite is committed to creating superior lighting control and energy management systems, setting new benchmarks in performance and efficiency.



Please contact your local Dynalite representative for information on specific applications.





To learn more about our control solutions
visit [dynalite.com](https://www.dynalite.com)

www.dynalite.com

© 2026 Signify Holding. All rights reserved. Specifications are subject to change without notice. No representation or warranty as to the accuracy or completeness of the information included herein is given and any liability for any action in reliance thereon is disclaimed. Dynalite and Signify Dynalite are registered trademarks of Signify Holding. All other trademarks are owned by Signify Holding or their respective owners. Data subject to change.